

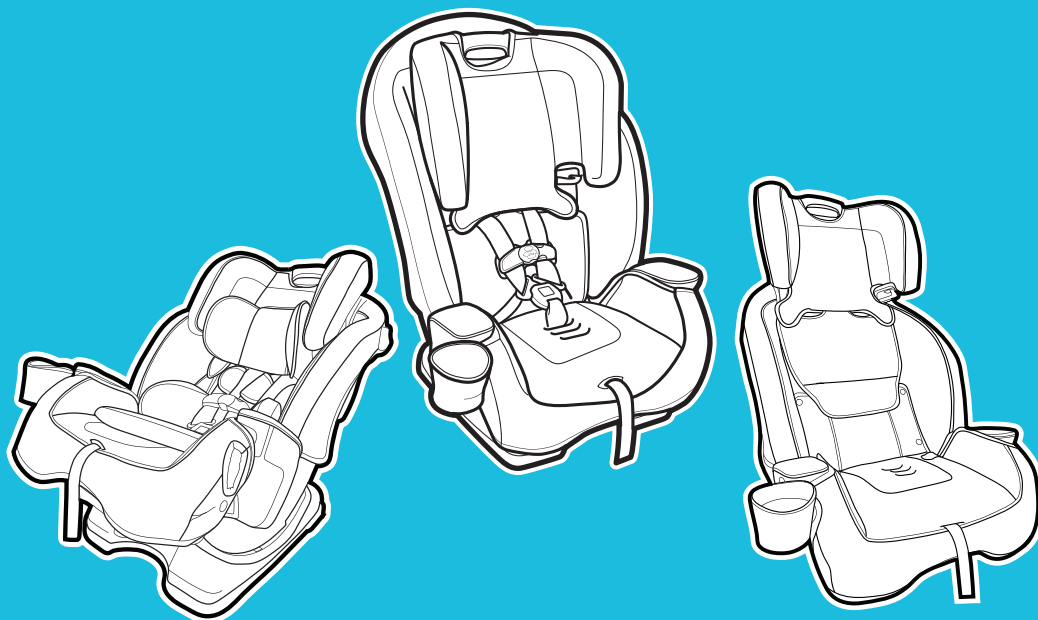

MILESTONE™ / LANDMARK™

3-IN-1 CAR SEAT

Read This Instruction Manual



Do not install or use this child restraint until you read and understand the instructions in this manual.

FAILURE TO PROPERLY USE THIS CHILD RESTRAINT INCREASES THE RISK OF SERIOUS INJURY OR DEATH IN A SUDDEN STOP OR CRASH.

1 Important

Pages 4-14

- 1-A A Quick Guide to Your Manual**
- 1-B Welcome to the Graco Family!**
- 1-C Height and Weight Guidelines**
- 1-D Before You Begin**
 - Register This Car Seat
 - If You Need Help
 - Certification
 - Car Seat's Useful Life
 - Vehicle Seat Protection
 - Warm Weather Use
- 1-E Safety Warnings**

2 Features

Pages 15-17

3 Rear-Facing Use

Pages 18-25

- 3-A Rear-Facing**
- 3-B Install Rear-Facing With InRight™ Lower Anchor Attachment**
- 3-C Install Rear-Facing With Vehicle Seat Belt**

4 Forward-Facing Use

Pages 26-32

- 4-A Forward-Facing**
- 4-B Install Forward-Facing With InRight™ LATCH**
- 4-C Install Forward-Facing With Vehicle Seat Belt**

5 Booster Use

Pages 33-39

- 5-A Highback Booster Use**
- 5-B Highback Booster Install**

6 Securing Child

Pages 40-45

6-A Securing Child With 5-point Harness

6-B Securing Child In Booster

7 Moving Lower Anchor Attachment

Pages 46-48

8 Accessories

Pages 49-50

9 Additional Information

Pages 51-58

9-A Choosing Vehicle Seat Location

9-B Unsafe Vehicle Seat Locations

9-C What is LATCH?

9-D Choosing Lower Anchor Attachment or Seat Belts

9-E How to Remove Lower Anchors and Tether

9-F Vehicle Seat Belts

10 Care & Cleaning

Pages 59-61

10-A Cleaning Seat Pad

10-B Cleaning Crotch Buckle

10-C Cleaning Harness, Lower Anchor and Tether



1 Important

1-A A Quick Guide to Your Manual

This car seat is for children: *Rear-Facing: 5-40 lb (2.3-18 kg)*

Forward Facing: 22-65 lb (10-30 kg)

Booster: 40-100 lb (18.1-45 kg)

- Children less than 22 lb (10 kg) **MUST** use this car seat rear-facing. Review section 1-C for more information.

Get to Know Your Car Seat

Review section 2-A to see all of the features of this car seat.

What Seating Location Should I Use?

The best seating location for this car seat is one that:

- Is recommended by your vehicle owner's manual, and
- Results in a secure installation of this car seat.

Some vehicles have specific requirements for where the car seat can be installed, so be sure to check your vehicle owner's manual for available seating positions, if any.

Review section 9-A, 9-B of this manual AND your vehicle owner's manual.

According to accident statistics, the safest place for your child in any vehicle is the back seat. The center of the back seat can be the safest during a possible side impact.

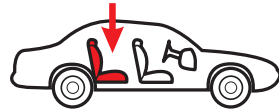

Which Installation Method Should I Use?

This car seat can be installed in your vehicle using either the vehicle seat belt **OR** the LATCH system. Both are equally safe to use. **DO NOT USE BOTH AT THE SAME TIME.**

Vehicle Seat Belt: Review section 9 and your vehicle owner’s manual to learn how to install your car seat with the vehicle seat belts.

LATCH or Lower Anchor Attachment: The LATCH system or Lower Anchor Attachment allows you to securely attach your safety seat in your car without using the vehicle seat belt and possibly to get a better fit. All 2003 and newer model year vehicles are required to have a LATCH system, although some manufacturers began including LATCH earlier. Some vehicle owner manuals use the term ISOFIX to identify the LATCH system.

What is LATCH?

LATCH consists of lower anchors and tether anchors, which are built-in to your vehicle, and connecting hooks that are built-in to your car seat. Lower anchors are used **INSTEAD** of the vehicle’s seat belt to secure the child seat to the vehicle. The Tether is used **IN ADDITION** to the lower anchors **OR** the vehicle’s seat belt to secure a forward-facing car seat to the vehicle.

Review your vehicle’s owner manual for exact location and use.

Vehicle Tether Anchor Points

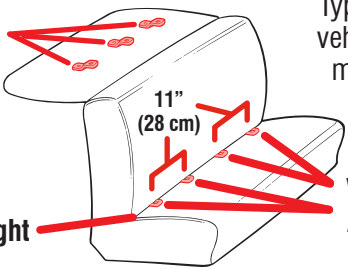

Typical seat in a passenger vehicle. Other vehicle types may have different lower anchor and tether locations.

Vehicle Seat Belt

Vehicle Lower Anchor Points



When Installing This Car Seat

Lower Anchor Attachment

The Lower Anchor Attachment consists of two lower anchors, which are built-in to your vehicle, and connecting hooks that are built-in your car seat. Review section 3-B, 4-B & 5-B of this manual AND your vehicle owner's manual.

Lower anchors can ONLY be used if the vehicle lower anchor spacing is 11 inches (28 cm) from the center of one lower anchor to the center of the other lower anchor.

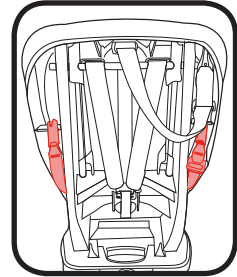
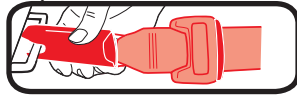

Vehicle Seat Belt

There are two types of vehicle seat belts that can be used When Installing Rear-Facing & Forward-Facing. Lap/Shoulder Seat Belt or Lap Only Seat Belt.

Only use the Lap/Shoulder seat belt configuration when Installing As a Booster

Review section 3-C, 4-C & 5-B of this manual AND your vehicle owner's manual.

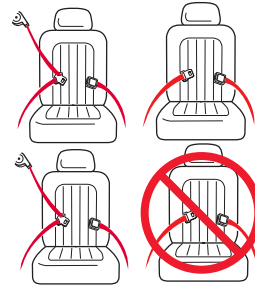

Does Your Car Seat Fit Your Child Correctly?

To make sure your child is secured properly, review section 3, 4 & 5 to understand all of the actions you need to take to properly adjust the car seat to fit your child.

For Rear-Facing, You Need to Adjust:

Harness Height, Rear-Facing (A)

Harness straps at or just below the child's shoulders and top of head **must** be 1" (2.5 cm) below the headrest adjustment lever (B). Review section 6.

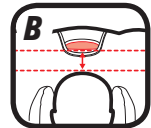

Buckle Position (C)

The correct slot is the one that is closest to your child without being underneath them. Review section 6.

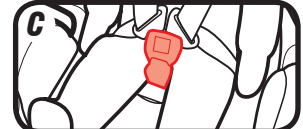

Harness Tightness (D)

If your fingers slide off the harness straps without pinching the straps, it is tight enough. Review section 6.

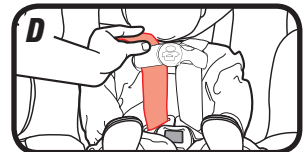

For Forward-Facing, You Need to Adjust:

Harness Height, Forward-Facing (A)

Harness straps at or just above the child's shoulders and top of child's ears below top of headrest **(B)**. Review section 6.

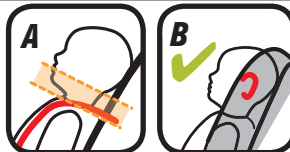

Buckle Position (C)

The correct slot is the one that is closest to your child without being underneath them. Review section 6.

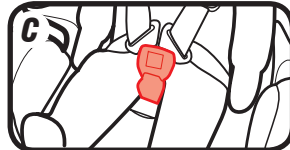

Harness Tightness (D)

If your fingers slide off the harness straps without pinching the straps, it is tight enough. Review section 6.

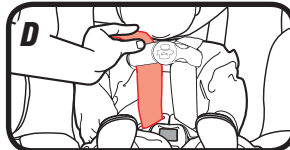

For Booster, You Need to Adjust:

Use Lap/Shoulder Belt Only

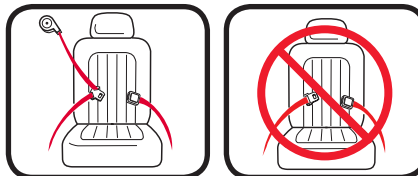

Position Lap Belt

Lap belt must go behind armrest and lie low across your child's hips and thighs.

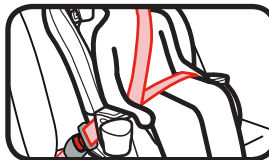

Position Shoulder Belt

Shoulder belt lies across shoulder between neck and edge of shoulder.

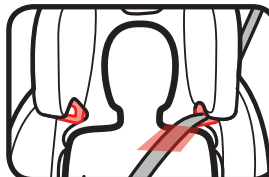

Rear-Facing Installation

Car Seat Does Not Move More than 1” (2.5 cm) at the Belt Path (A)

Review section 3

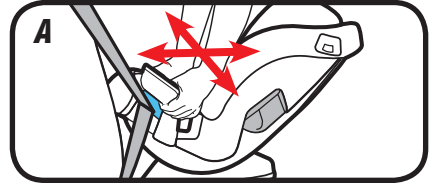

Check level indicator (B)

Review section 3

Harness Straps at or Just Below Child’s Shoulders (C)

Review section 6

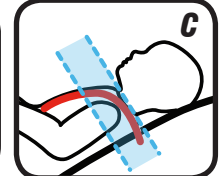

Chest Clip Even With Armpits (D)

Review section 6

Cannot Pinch Harness Straps at the Shoulder (E)

Review section 6

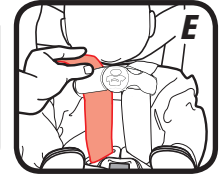
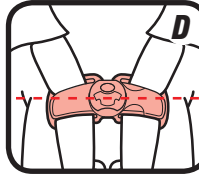

Forward-Facing Installation

Use the tether strap when using forward-facing (A)

When used properly, the tether helps reduce injury in a sudden stop or crash.

Review section 4

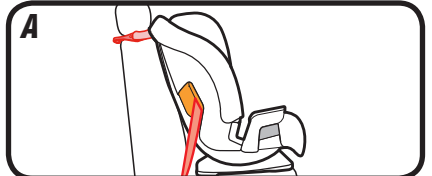

Car Seat Does Not Move More than 1” (2.5 cm) at the Belt Path (B)

Review section 4

Harness Straps at or Just Above Child’s Shoulders (C)

Review section 6

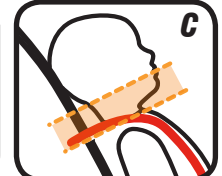

Chest Clip Even With Armpits (D) Review section 6

Cannot Pinch Harness Straps at the Shoulder (E)

Review section 6

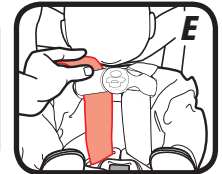
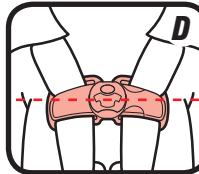

Booster Installation

Never Use Lap Belt Only

Review section 5



Lap Belt Behind Armrest and Lies Low Across Hips and Thighs

Review section 5

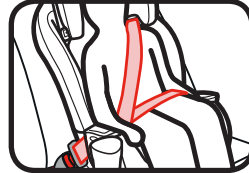

Shoulder Belt Lies On the Shoulder, Between the Neck and Edge of Shoulders

Review section 5

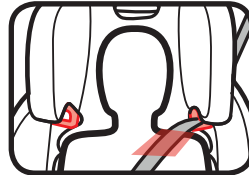

1 Important



1 Important

1-B Welcome to the Graco Family!

Your child's safety depends on you. No car seat can guarantee protection from injury in every situation, but proper use helps reduce the risk of serious injury or death.

Even if this car seat seems easy to figure out on your own, you must follow the detailed instructions in this instruction manual to ensure all steps are preformed correctly.

1-C Height and Weight Guidelines

5 lb (2.3 kg)	22 lb (10 kg)	40 lb (18 kg)	65 lb (30 kg)	100 lb (45 kg)
------------------	------------------	------------------	------------------	-------------------

Rear-Facing with 5-Point Harness
Must be 49" (125 cm) or less:
 5-22 lb (2.3-10 kg) and less than 1 year old **MUST** be rear-facing.
 22-40 lb (10-18 kg) **SHOULD** be rear-facing.*

Forward-Facing with 5-Point Harness
Must be 49" (125 cm) or less:
 22-40 lb (10-18 kg) and can sit upright unassisted **CAN** be forward-facing.
 40-65 lb (18-30 kg) **SHOULD** be forward-facing.*

Booster Mode with Vehicle Lap/Shoulder Seat Belt
Must be 43-57" (110.1-145 cm) tall and 4+ years old
 40-65 lb (18.1-30 kg) **CAN** be in booster mode.
 Over 65 lb (30 kg) **MUST** be in booster mode.*

*Check your state laws and the AAP/NHTSA recommendations. See page 13.

Note: Preterm or low birth weight infants may be at special risk in a vehicle or aircraft. According to the AAP, these infants may suffer breathing issues if improperly reclined in a car seat. When rear-facing, use the corrected age for preemies. Graco advises that you have your physician or hospital staff evaluate your infant and recommend the proper car seat or car bed before you and your infant leave the hospital.

1-D Before You Begin



1 Important

Register This Child Restraint

Please fill out the prepaid registration postcard attached to the harness and mail it in today **or register online at www.gracobaby.com/carseatregistration.**

Child restraints could be recalled for safety reasons. You must register this restraint to be reached in a recall. Send your name, address, and the restraint's model number and manufacturing date to:

Graco Children's Products, Inc.
Attn: Customer Service
P.O. Box 169, Elverson, PA 19520-9901
or call 1-800-345-4109
or register online at
www.gracobaby.com/carseatregistration

For recall information, call the U.S. Government's Vehicle Safety Hotline at 1-888-327-4236 (TTY: 1-800-424-9153), or go to <http://www.NHTSA.gov>.

For future reference or if you change addresses, record the model name, model number, date of manufacture, and purchase date of this car seat below. You can find this information either on the registration card if you still have it or on the date label located on the back of the car seat.

Model Name _____
Model Number _____
Date of Manufacture _____
Date of Purchase _____

If You Need Help

In the U.S.A, please contact our Customer Service Department with any questions you may have concerning parts, use, or maintenance. When you contact us, please have your product's model number and date of manufacture ready so that we may help you efficiently. These numbers can be found on a sticker on the back side of your car seat.

For additional resources or to get your car seat checked by a child passenger safety technician, please visit the following web sites:

www.nhtsa.gov • www.seatcheck.org • www.safekids.org



1 Important

Certification

This child restraint meets or exceeds all applicable requirements of Federal motor vehicle safety standard 213 for use in motor vehicles.



This child restraint is certified for use in aircraft only when used with the internal harness system. Use only forward-facing aircraft seats. Follow the instructions for vehicle installation. See sections 3-C or 4-C and 9-F Lap Belt Installation, but do not use the tether.



This child restraint is NOT certified for aircraft use when used as a booster seat because aircraft do not have shoulder belts.

Contact the airline for their specific policies.

Car Seat's Useful Life

STOP using this car seat and throw it away 10 years after the date of manufacture. Look for date of manufacture label on back of the car seat.

Graco Children's Products Inc. advises against loaning or passing along a car seat unless you know the complete history of the product. We also advise against purchasing a car seat second hand.

Vehicle Seat Protection

Protect vehicle seat. Use a car seat mat, towel, or thin blanket under and behind car seat.

Warm Weather Use

Car seat parts can get very hot in the sun or warm weather. **To avoid burns, always check before putting child in car seat.**

1-E Safety Warnings



1 Important

No car seat can guarantee protection from injury in every situation, but proper use helps reduce the risk of serious injury or death. **READ THIS MANUAL CAREFULLY.**

⚠ WARNING!

Failure to follow these instructions and child restraint's labels can result in child striking the vehicle's interior during a sudden stop or crash.



! NEVER PLACE THIS CHILD RESTRAINT REAR-FACING IN A VEHICLE SEATING LOCATION THAT HAS AN ACTIVE FRONT AIR BAG.

If an air bag inflates, it can hit the child and car seat with great force and cause serious injury or death to your child.

! Review your vehicle owner's manual for more information about air bags and car seat use.

! If your vehicle does not have a back seat, review your vehicle owner's manual.

! Children are safer riding rear-facing and should ride rear-facing as long as possible, until they reach the maximum rear-facing height or weight rating for their car seat. Then children should ride forward-facing, using the built-in harness system for as long as possible until they reach the maximum forward-facing weight or height for their car seat. At that point, children should ride in a belt-positioning booster seat. A booster is no longer needed once the vehicle seat belt fits properly, typically when they reach 4 feet 9 inches (145 cm) tall and are between ages 8-12. Be sure to check your local and state laws, as well as AAP and NHTSA recommendations, for car seat usage.*

*Graco Supports the American Academy of Pediatrics and National Highway Traffic Safety Administration's Car Seat Guidelines. Visit www.gracobaby.com/en-US/safety for information on car seat usage recommendations.

! Choose the correct mode of use for the car seat depending on your child's size. Infants less than 22 lb (10 kg) MUST use this car seat rear-facing.

! Select a suitable location for the car seat in your vehicle.

! Secure car seat with a vehicle seat belt or the lower anchor attachment that is properly routed as shown in this manual.

! Vehicle seat belt system MUST hold car seat securely. Not all vehicle seat belts can be used with a car seat.

! If vehicle seat belt does not hold car seat securely, read "Vehicle Seat Belts" section 9-F and your vehicle owner's manual.

! Always secure car seat with the lower anchor attachment or a vehicle seat belt, even when unoccupied. In a crash, an unsecured car seat can injure passengers.

! If car seat is in a crash, it must be replaced. DO NOT use it again! A crash can cause unseen damage and using it again could result in serious injury or death.

! DO NOT use car seat if it is damaged or missing parts.

! DO NOT use accessories or parts other than those provided by Graco except for a thin towel or mat to protect your vehicle seat or a rolled towel or pool noodles to help get your car seat level. Their use could alter the performance of the car seat.

! DO NOT remove LATCH system from car seat. If using vehicle seat belt to secure car seat, lower anchor hooks must be stored.

! Never leave child unattended, even when sleeping. Child may become tangled in harness straps and suffocate or strangle.

! Rear-facing car seat must be properly leveled:

- Too reclined can result in injury or ejection.
- Too upright can result in breathing difficulties.



! Never attach two lower anchor connectors to one vehicle lower anchor unless specifically allowed by the vehicle manufacturer.

! Do not use both the vehicle seat belt and lower anchor attachment at the same time when using the car seat with the 5-point harness.

2-A Car Seat Features

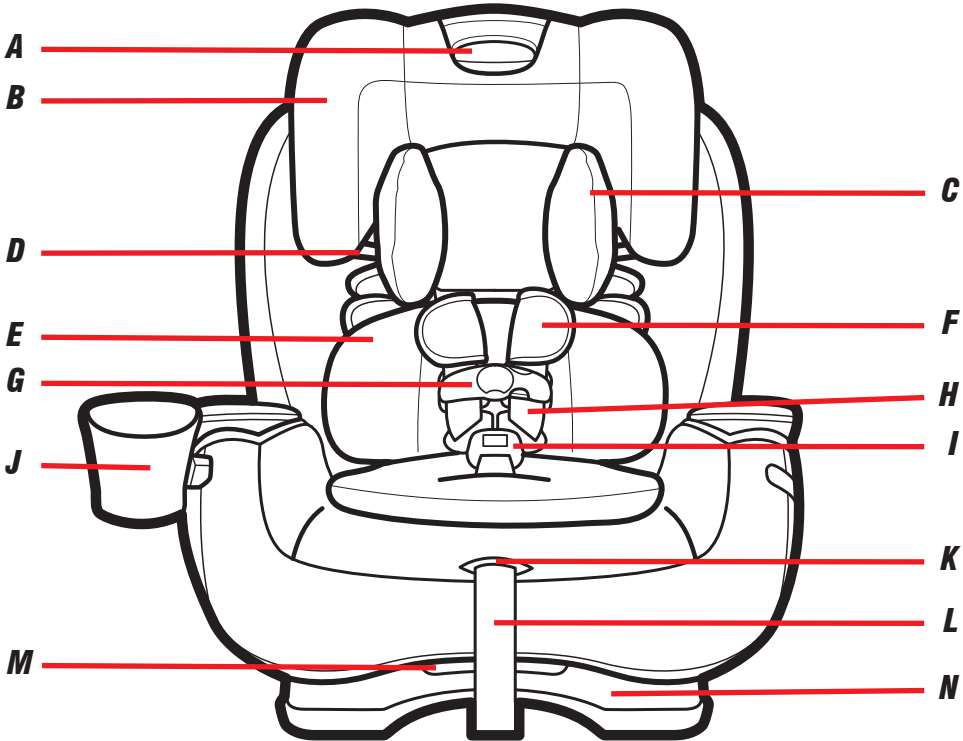

- A Headrest/Harness Adjustment Handle**
- B Headrest**
- C Infant Head Support**
- D Booster Shoulder Belt Guide**
- E Infant Body Support**
- F Harness Covers**
- G Chest Clip**

- H Harness Straps**
- I Buckle**
- J Cup Holder**
- K Harness Release Lever
(under seat pad)**
- L Harness Adjustment Strap**
- M Recline Handle**
- N Seat Base**

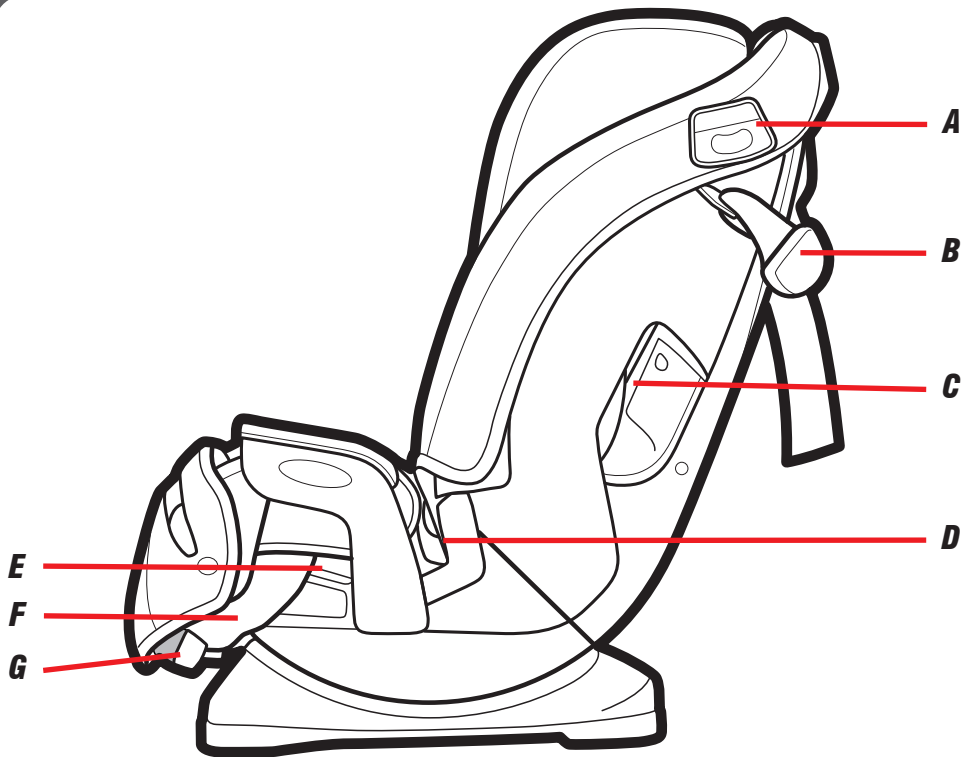

- A Rear-Facing Level Indicator***
- B Tether***
- C Forward-Facing Belt Path***
- D Booster Lap Belt Path***
- E Rear-Facing Belt Path***
- F Lower Anchor Attachment***
- G Lower Anchor Attachment Storage***

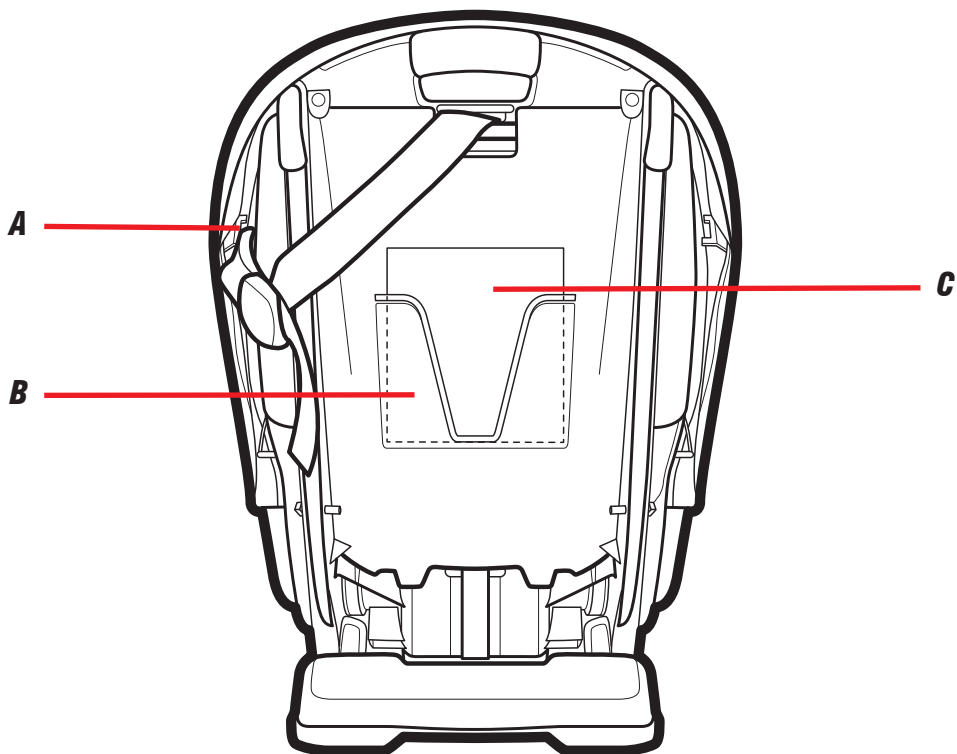

A Tether Strap Storage

B Instruction Manual Storage

C Instruction Manual

3-A Rear-Facing

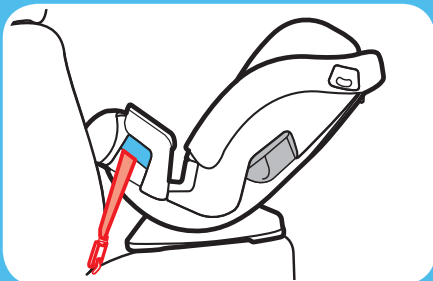

Lower Anchor Strap

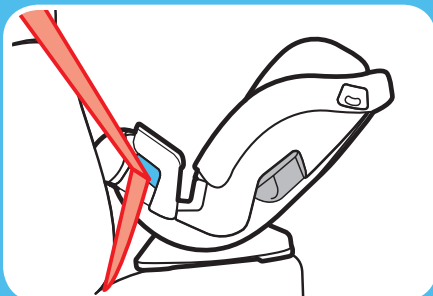

Vehicle Lap/Shoulder Seat Belt

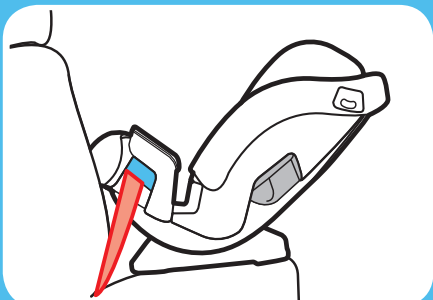

Vehicle Lap Only Seat Belt

Rear-Facing: 5-40 lb (2.3-18 kg) and whose head is at least 1" (2.5 cm) below the headrest adjustment handle

- Car seat must be rear-facing in the vehicle back seat.
- Make sure the lower anchor strap or vehicle seat belt is routed through the rear-facing belt path, marked with a blue label.
- Install this car seat tightly in your vehicle. Car seat **should not move** at the rear-facing belt path more than 1" (2.5 cm) from side to side and front to back.
- Check rear-facing level indicator to make sure the ball is within the blue zone. Vehicle **MUST** be on level ground.
- Harness straps must be **at or just below** the top of child's shoulders and chest clip must be at **armpit level**.
- Infants who weigh less than 22 lb (10 kg) **MUST be rear-facing**.
- Children are safer riding rear-facing and should ride rear-facing as long as possible, until they reach the maximum rear-facing height or weight rating for their car seat. Then the children should ride forward-facing, using the built-in harness system for as long as possible until they reach the maximum forward-facing weight or height for their car seat. Be sure to check your local and state laws, as well as AAP and NHTSA recommendations, for car seat usage.

⚠ WARNING!



NEVER place this child restraint rear-facing in a vehicle seating location that has an active front air bag.

3-B Install Rear-Facing With InRight™ Lower Anchor Attachment

Review your vehicle's owner manual for Lower Anchor location and use.

1. Make Sure Lower Anchor Strap is in the Rear-Facing Belt Path, Marked With a Blue Label

If it is not, see section 7-A to move Lower Anchor strap.

2. Recline the Car Seat

Place the car seat in recline position 1 or 2.

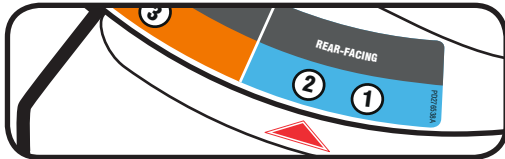

3. Remove Lower Anchor Connectors from Storage Location

Push in on the red buttons on the Lower Anchor connectors and remove from storage location.

4. Extend the Lower Anchor Strap

For easier installation, extend the Lower Anchor strap to its maximum length by pressing the gray button and pulling on the strap.

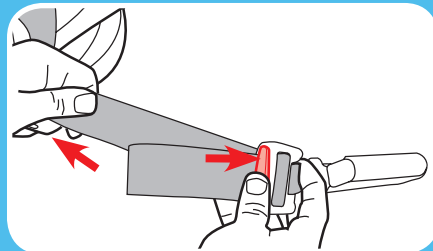
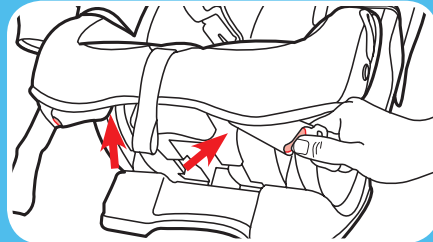
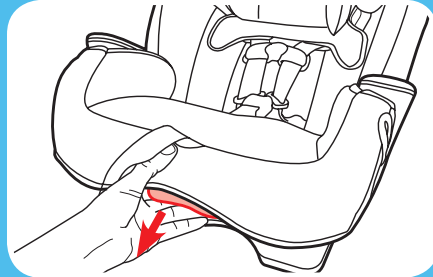
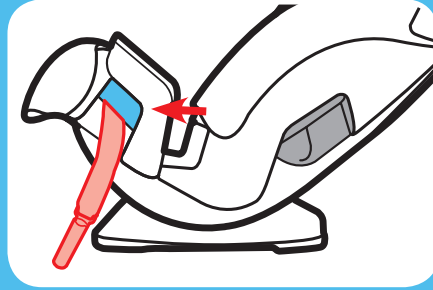

3 Rear Facing

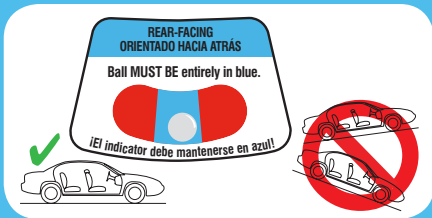
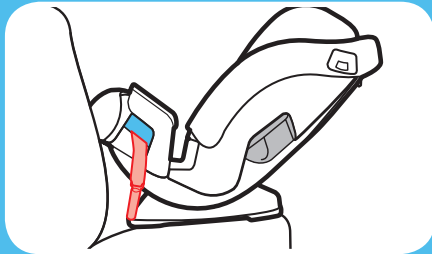

5. Place Car Seat Rear-Facing in Back Seat of the Vehicle

Place the base flat on the vehicle seat. Push it back until the front of the car seat touches the vehicle seat back. Center the car seat between the lower anchors.

6. Check the Rear-Facing Level Indicator

Vehicle **MUST** be on level ground. **Ball must be completely in the blue zone.** Readjust the incline if needed. Or if needed, rolled towels may be placed under the car seat at the vehicle seat crease, until the ball is completely in the blue zone.

7. Connect Lower Anchor Connectors to Vehicle's Lower Anchors.

Lower anchor strap should lay as flat as possible and not be twisted.

Lower anchors can only be used if the vehicle lower anchor spacing is 11 inches (28 cm) from the center of one lower anchor to the center of the other lower anchor.

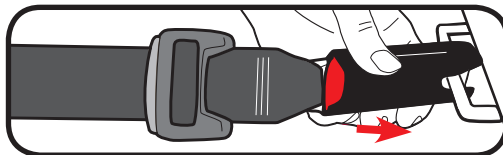

8. Tighten the Lower Anchor Strap

Press down firmly in the center of the car seat while tightening the lower anchor strap.

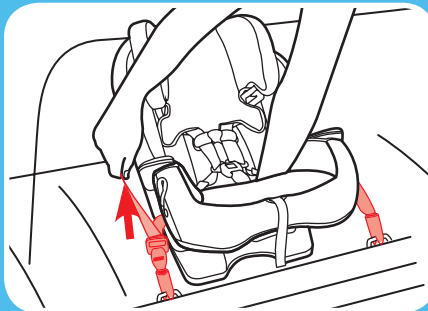

Note: For easier tightening, you may need to pull the tail of the lower anchor strap through the belt path as shown.

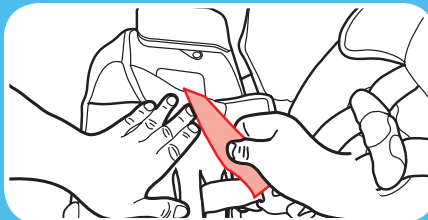

9. Test For Tightness

Grab the sides of the seat where the lower anchor strap is and slide the car seat side to side and front to back.

If the seat moves less than 1" (2.5 cm), it is tight enough.

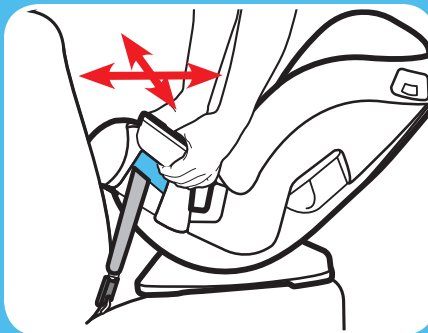

3 Rear
Facing

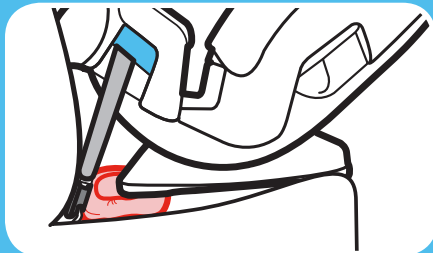
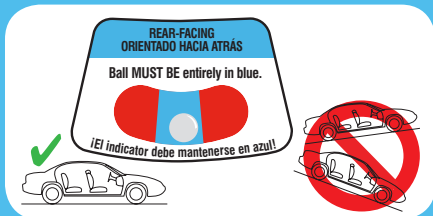

10. Check the Rear-Facing Level Indicator

Vehicle **MUST** be on level ground. **Ball must be completely in the blue zone.** Readjust the incline if needed. Or if needed, rolled towels may be placed under the car seat at the vehicle seat crease, until the ball is completely in the blue zone.

See section 6-A to secure your child.

Recheck the level indicator with child in seat.

3-C Install Rear-Facing With Vehicle Seat Belt

1. Recline the Car Seat

Place the car seat in recline position 1 or 2.

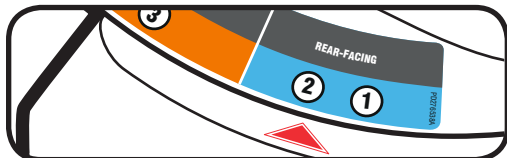

2. Store Tether and Lower Anchor Connectors

Store tether hook as shown. Push in on the red buttons and attach the Lower Anchor connectors to plastic bar as shown. Remove the slack from both straps.

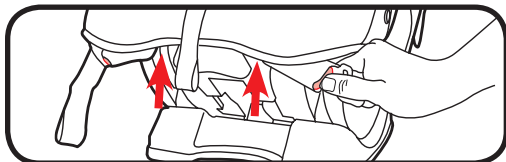

3. Place Car Seat Rear-Facing in Back Seat of the Vehicle

Place the base flat on the vehicle seat. Push it back until the front of the car seat touches the vehicle seat back.

4. Check the Rear-Facing Level Indicator

Vehicle **MUST** be on level ground. **Ball must be completely in the blue zone.** Readjust the incline if needed. Or if needed, rolled towels may be placed under the car seat at the vehicle seat crease, until the ball is completely in the blue zone.

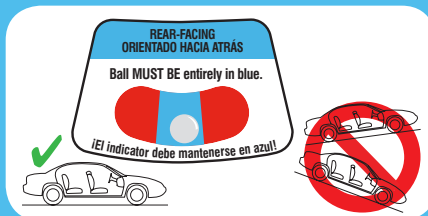
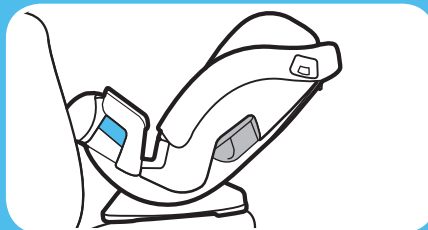
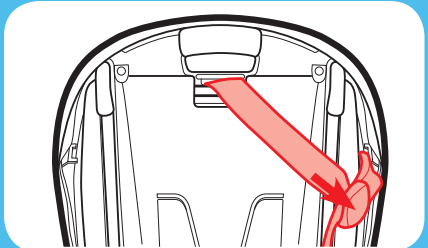
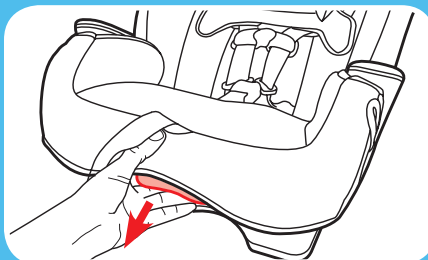

3 Rear Facing

Review your vehicle's owner manual for vehicle seat belt use

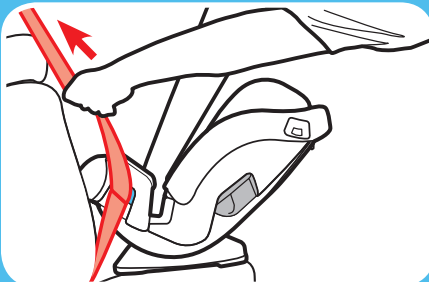
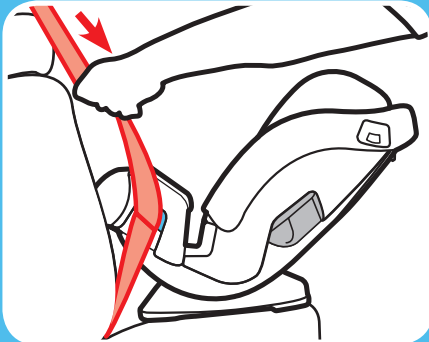
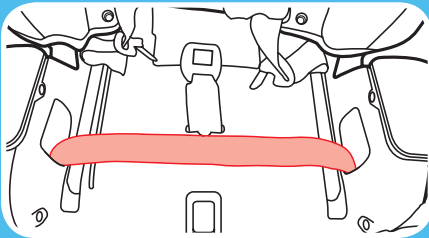
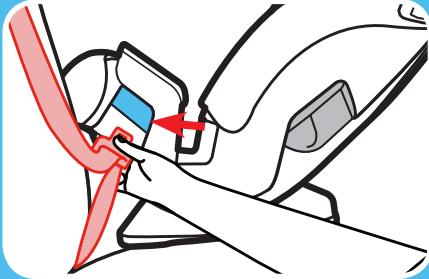

5. Route the Vehicle Seat Belt

Thread vehicle seat belt through the rear-facing belt path (marked with a blue label) and buckle it. The seat belt should lay as flat as possible and not be twisted.

Note: It may be easier to route the vehicle seat belt by lifting seat pad up to expose the belt path.

Make sure vehicle seat belt is in front of the buckle strap.

6. Lock the Vehicle Seat Belt

In most vehicles today, slowly pull the shoulder belt all the way out and then let it go back in. You will hear a clicking sound. Slowly pull out on the belt and it should be locked. If not, review your car's owner manual and section 9-F.

7. Tighten the Vehicle Seat Belt

Press down firmly in the center of the car seat. Pull on the shoulder belt to tighten while feeding the slack back in the retractor.

3 Rear Facing

8. Test For Tightness

Grab the sides of the seat where the vehicle seat belt is and slide the car seat side to side and front to back.

If the seat moves less than 1" (2.5 cm), it is tight enough.

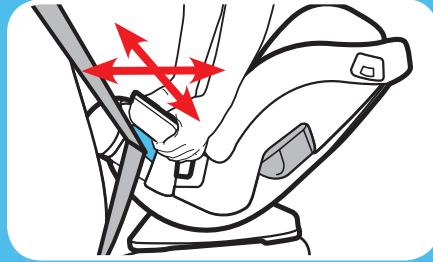

9. Check the Rear-Facing Level Indicator

Vehicle **MUST** be on level ground. **Ball must be completely in the blue zone.** Readjust the incline if needed. Or if needed, rolled towels may be placed under the car seat at the vehicle seat crease, until the ball is completely in the blue zone.

See section 6-A to secure your child.

Recheck the level indicator with child in seat.

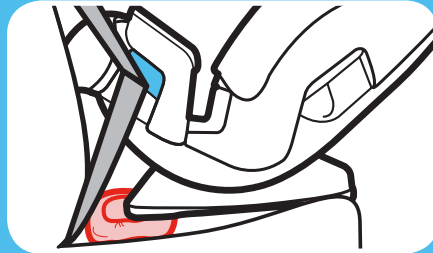
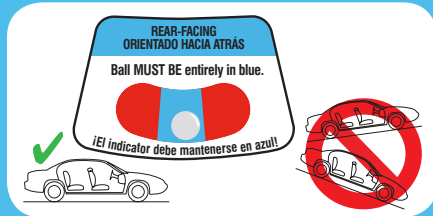

3 Rear Facing

4-A Forward-Facing

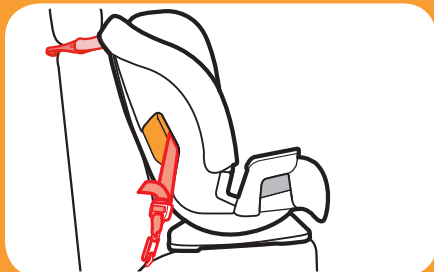

LATCH

Do not install by this method for a child weighing more than 45 lb (20 kg)

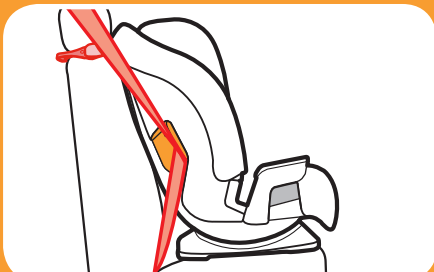

Vehicle Lap/Shoulder Seat Belt with the Tether Strap

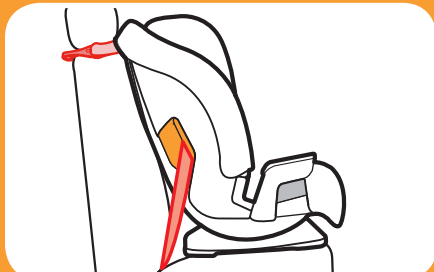

Vehicle Lap Only Seat Belt with the Tether Strap

**Forward-Facing:
22-65 lb (10-30 kg) and
49" (125 cm) or less**

- Car seat must be forward-facing in the vehicle back seat.
- Make sure the lower anchor strap or vehicle seat belt is routed through the forward-facing belt path, marked with an orange label.
- Install this car seat tightly in your vehicle. Car seat **should not move** at the forward-facing belt path more than 1" (2.5 cm) from side to side and front to back.
- Attach and tighten the tether strap. When used properly, the tether helps reduce injury in a sudden stop or crash.
- Harness straps must be **at or just above** the top of child's shoulders and chest clip must be **at armpit level**.
- Children are safer riding rear-facing and should ride rear-facing as long as possible, until they reach the maximum rear-facing height or weight rating for their car seat. Then children should ride forward-facing, using the built-in harness system for as long as possible until they reach the maximum forward-facing weight or height for their car seat. At that point, children should ride in a belt-positioning booster seat. Be sure to check your local and state laws, as well as AAP and NHTSA recommendations, for car seat usage.

4-B Install Forward-Facing With InRight™ LATCH

Review your vehicle's owner manual for LATCH location and use.

1. Make Sure the Lower Anchor Strap is in the Forward-Facing Belt Path, Marked with Orange Label

If it is not, see section 7-A to move the lower anchor strap.

2. Recline the Car Seat

Place the car seat in recline position 3 or 4.

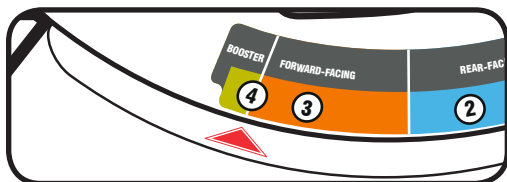

3. Remove Lower Anchor Connectors and Tether Straps from Storage Locations

Push in on the red buttons on the lower anchor connectors and remove from storage position. Unhook tether and lay it in the seat.

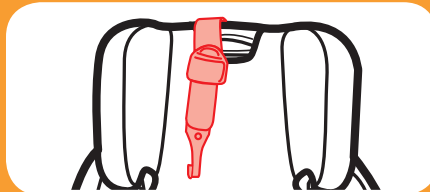
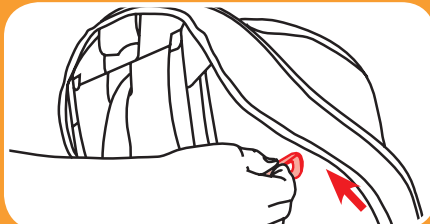
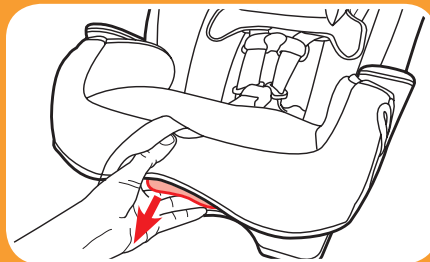
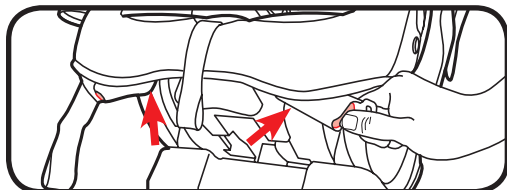

4 Forward Facing

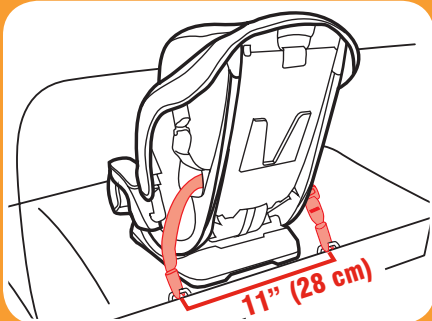
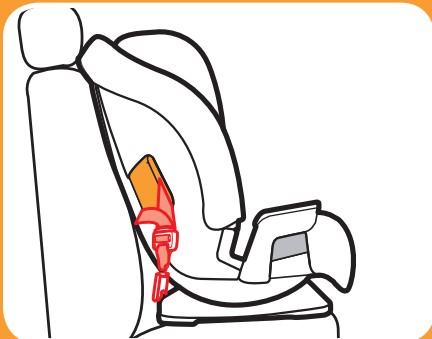
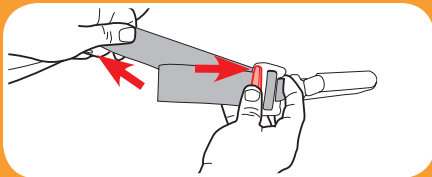

4. **Extend the Lower Anchor Strap**

For easier installation, extend the Lower Anchor strap to its maximum length by pressing the gray button and pulling out on the strap.

5. **Place Car Seat Forward-Facing in Back Seat of the Vehicle**

Place the base flat on the vehicle seat. Push it back firmly until the back of the car seat touches the vehicle seat back. Center the car seat between the lower anchors.

6. **Connect the Lower Anchor Connectors to Vehicle's Lower Anchors.**

The Lower Anchor strap should lay as flat as possible and not be twisted.

The Lower Anchors can only be used if the vehicle lower anchor spacing is 11 inches (28 cm) from the center of one lower anchor to the center of the other lower anchor.

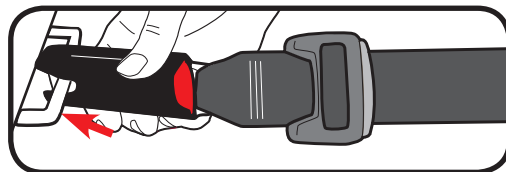

7. **Tighten the Lower Anchor Strap**

Press down firmly in the center of the car seat while tightening the Lower Anchor strap.

Note: For easier tightening, you may need to pull the tail of the Lower Anchor strap through the belt path as shown.

8. Attach Tether Strap

Extend the tether by lifting up on the tether lock and attach.

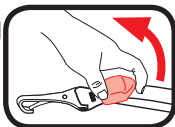

Consult vehicle's owner manual for specific location.

9. Tighten Tether Strap

Remove all the slack.

10. Test For Tightness

Grab the sides of the seat where the Lower Anchor strap is and slide the car seat side to side and front to back.

If the seat moves less than 1" (2.5 cm), it is tight enough.

See section 6-A to secure your child.

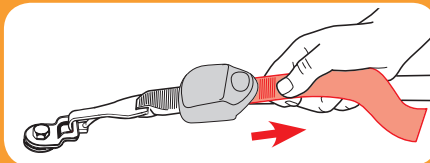
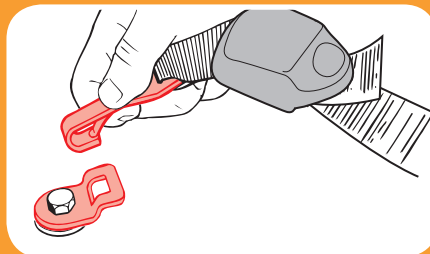
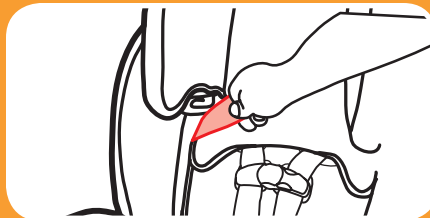

4 Forward Facing

4-C Install Forward-Facing With Vehicle Seat Belt

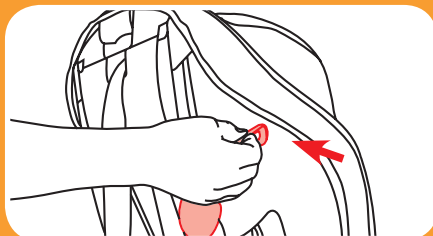
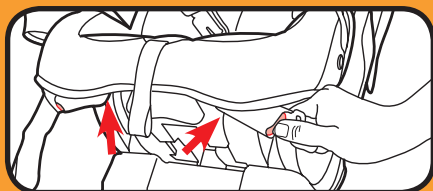
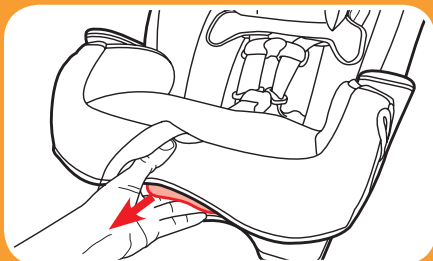

1. Recline the Car Seat

Place the car seat in recline position 3 or 4.

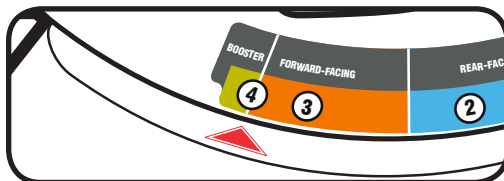

2. Store Lower Anchor Connectors

Push in on the red buttons and attach the Lower Anchor connectors to plastic bar as shown and remove the slack from the strap.

3. Place Car Seat Forward-Facing in Back Seat of the Vehicle

Place the base flat on the vehicle seat. Push it back firmly until the back of the car seat touches the vehicle seat back. Center the car seat between the lower anchors.

4. Unhook Tether Strap From Storage Location and Lay it in the Seat

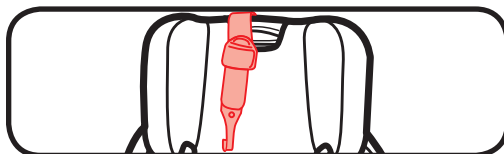

Review your vehicle's owner manual for vehicle seat belt use

5. Route the Vehicle Seat Belt

Thread vehicle seat belt through the forward-facing belt path (marked with an orange label) and buckle it. The seat belt should lay as flat as possible and not be twisted.

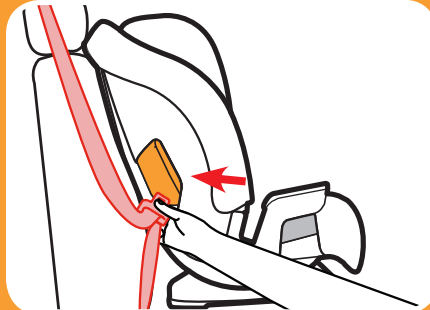

6. Lock the Vehicle Seat Belt

In most vehicles today, slowly pull the shoulder belt all the way out and then let it go back in. You will hear a clicking sound. Slowly pull out on the belt and it should be locked. If not, review your car's owner manual and section 9-F.

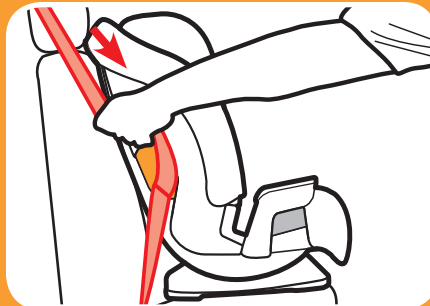

7. Tighten the Vehicle Seat Belt

Press down firmly in the center of the car seat. Pull on the shoulder belt to tighten while feeding the slack back in the retractor.

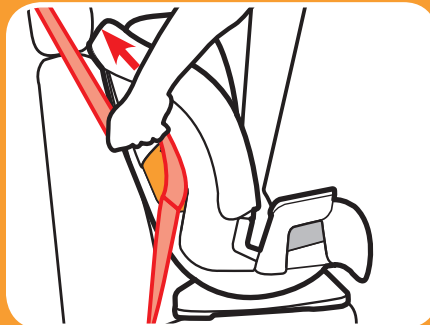

8. Attach Tether Strap

Extend the tether by lifting up on the tether lock and attach.

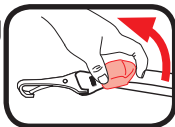

Consult vehicle's owner manual for specific location.

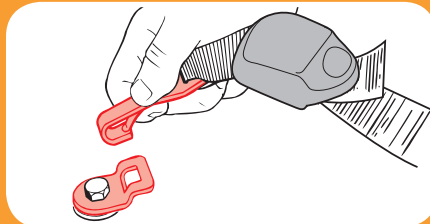

4 Forward Facing

9. Tighten Tether Strap

Remove all the slack.

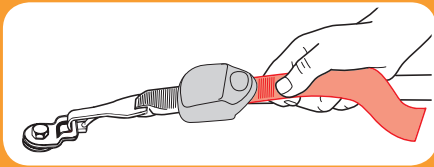

10. Test For Tightness

Grab the sides of the seat where the forward-facing belt path is and slide the car seat side to side and front to back.

If the seat moves less than 1" (2.5 cm), it is tight enough.

See section 6-A to secure your child.



5-A Highback Booster Use

Booster Use:

40-100 lb (18.1-45 kg)

43-57" (110.1-145 cm)

At least 4 years old

- Car seat must be forward-facing in the vehicle back seat.
- Vehicle seat belts **MUST** lay flat against child and **MUST NOT** be twisted.
- Make sure vehicle seat's lap belt is adjusted snugly, lays low on the child's hip, and is routed behind the armrest in the booster's belt path marked with a green label.
- Make sure vehicle seat's shoulder belt is centered between the child's neck and edge of shoulder.
- **Never** use a vehicle lap only seat belt across front of child.
- **DO NOT** position vehicle shoulder belt under the child's arm or back.
- **DO NOT** allow child to slouch or slide down in the booster seat.
- **DO NOT** position vehicle seat belt over top of armrests.
- When forward-facing, children should use the built-in harness system for as long as possible until they reach the maximum forward-facing weight or height for their car seat. A booster is no longer needed once the vehicle seat belt fits properly, typically when they reach 4 feet 9 inches (145 cm) tall and are between ages 8-12. Be sure to check your local and state laws, as well as AAP and NHTSA recommendations, for car seat usage.

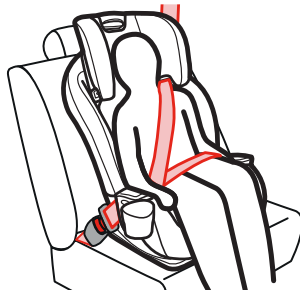

Vehicle Lap/Shoulder Seat Belt



Never use a vehicle lap only seat belt across front of child.



5 Booster



5 Booster



- Vehicle seat's headrest **SHOULD NOT** create a gap between vehicle seat and booster seat.
- The front of booster seat base **MUST NOT** hang over front of vehicle seat.
- If child will not keep the vehicle seat belt properly positioned, **DO NOT** use this booster seat. Use a different car seat.

5-B Highback Booster Install

1. Store the Harness

Loosen the harness straps as much as possible. (A)

Raise the headrest to the highest position. (B)

Unbuckle the chest clip and the buckle. (C and D)

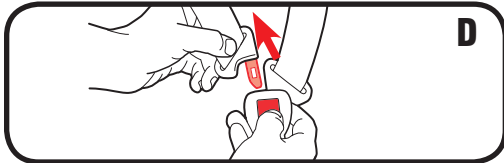
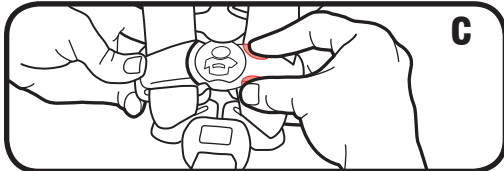
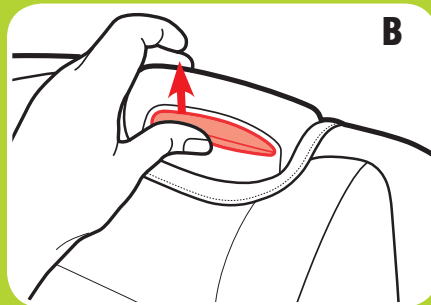
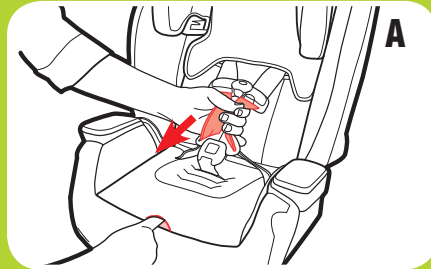

Remove the Lower Seat Pad to Expose the Harness Storage Door (E, F and G)

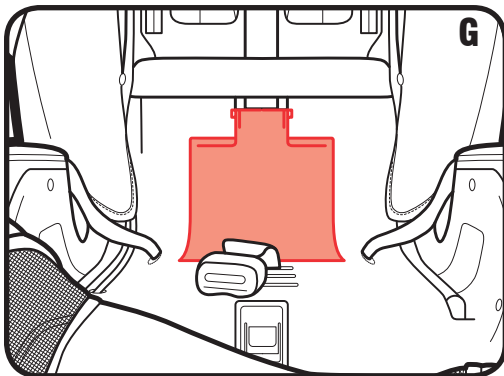
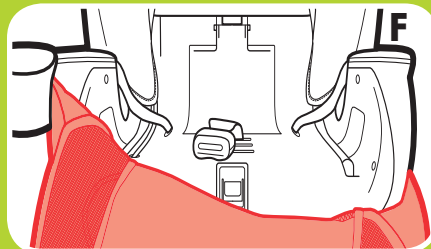
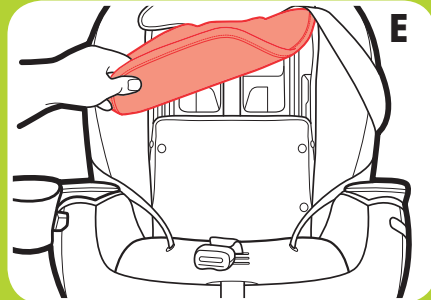

5 Booster

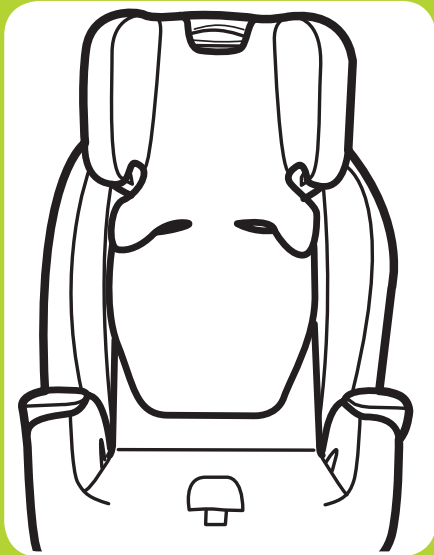
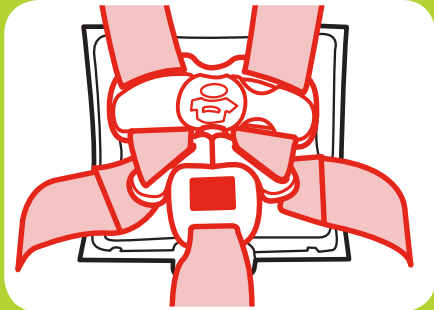
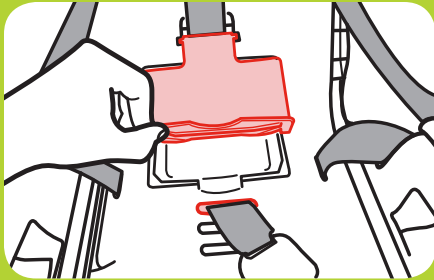

Move Buckle Strap to Rear Slot

Open the Harness Storage Door and Place Harness, Chest Clip, Buckle, and Buckle Tongues Inside Storage Compartment. Close the Door

Replace Seat Pad

Move the headrest back to its proper position for your child.

2. Recline the Car Seat

Place the booster seat in recline position 4.

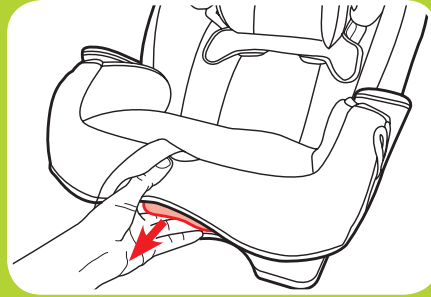
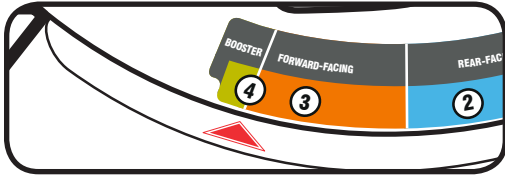

Graco allows the securing of the car seat with LATCH system in the booster mode. The child still **MUST BE SECURED** with the vehicle lap/shoulder seat belt. LATCH can be used in the booster mode regardless of the weight of the child up to 100 lb (45 kg).

Verify the following before using LATCH in the booster mode:

- The lower anchor attachment **DOES NOT** interfere with any vehicle seat belts or buckles.

If the lower anchor attachment interferes with the vehicle seat belts or if the chosen seating position does not have lower anchors, you **MUST** store the lower anchor connectors. Store the lower anchor connectors by attaching to the plastic bars as shown. Store the tether as shown. Always secure car seat with LATCH or a vehicle seat belt, even when unoccupied. In a crash, an unsecured car seat can injure passengers.

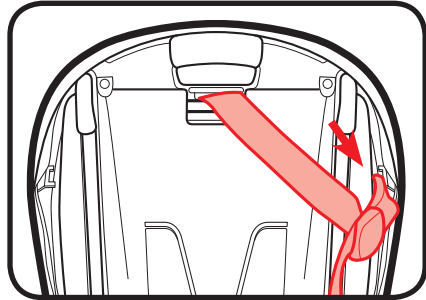
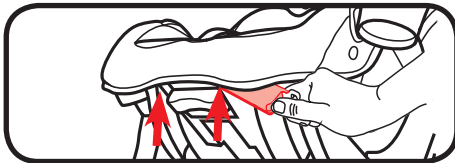

3. Place the Booster Seat Forward-Facing in the Back Seat of Vehicle

Place forward-facing on a vehicle seat that has a lap/shoulder seat belt. The base should sit as flat as possible on the vehicle seat.



Skip to Step 10 if Not Using LATCH



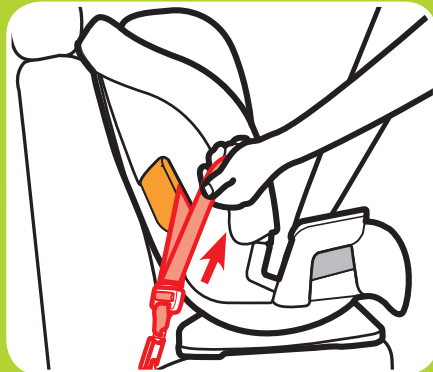
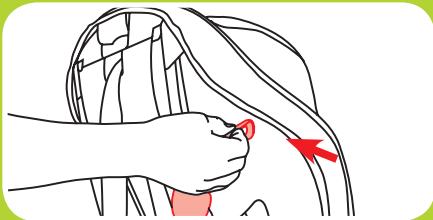

4. Make Sure the Lower Anchor Strap is in the Forward-Facing Belt Path, Marked with Orange Label

If it is not, see section 7-A to move the Lower Anchor strap.

5. Unhook Tether Strap From Storage Location and Lay it in the Seat

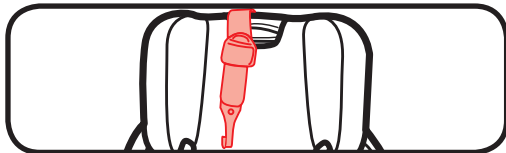

6. Connect the Lower Anchor Connectors to Vehicle's Lower Anchors.

The Lower Anchor strap should not be twisted.

The lower anchors can only be used if the vehicle lower anchor spacing is 11 inches (28 cm) from the center of one lower anchor to the center of the other lower anchor.

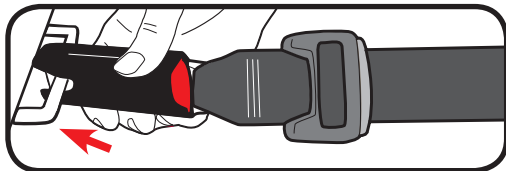

7. Tighten the Lower Anchor Strap

Remove all the slack.

8. Attach Tether Strap

Extend the tether by lifting up on the tether lock and attach.

Consult vehicle's owner manual for specific location.

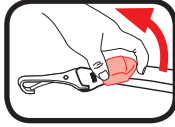

9. Tighten Tether Strap

Remove all the slack.

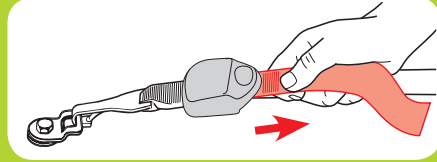
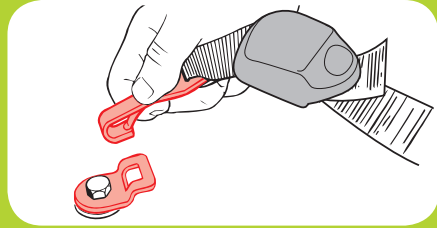

10. Thread the Vehicle Shoulder Belt Through Shoulder Belt Guide on the Headrest

See section 6-B to secure your child.

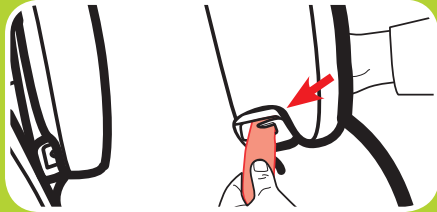

5 Booster

⚠️ WARNING!

WARNING! In cold weather, do not put snowsuits or bulky garments on your child when placing them in the car seat. Bulky clothing can prevent the harness straps from being tightened properly. To keep child warm, buckle your child in the car seat and place a blanket around the child or place the child's coat on backwards after buckling in.



6-A Securing Child With 5-point Harness

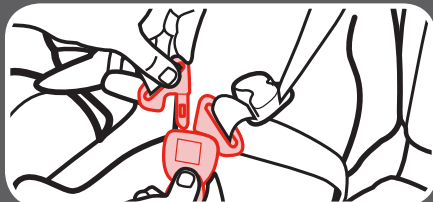
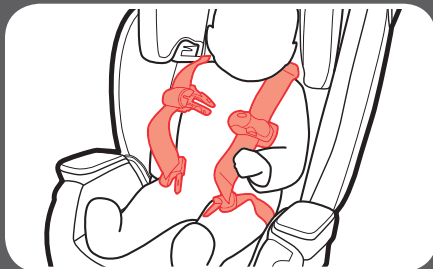
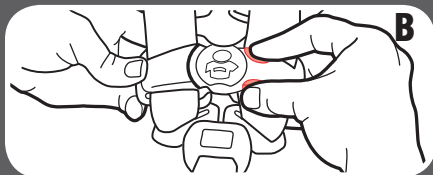
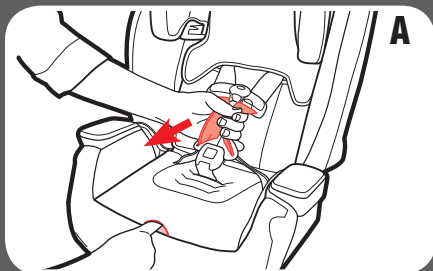

1. Loosen Harness Straps

Push down on the harness release lever while pulling out on the harness straps at the chest clip. (A)

Unbuckle the chest clip (B) and the buckle (C). Place harness straps off to the sides.

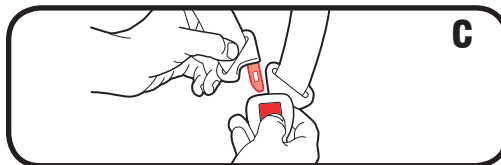

2. Place Your Child in the Seat

Make sure their back is flat against the car seat back.

3. Place Harness Straps Over Child's Shoulders and Buckle

You will hear a "click" when buckle tongues are securely attached. Pull up on each buckle tongue to make sure it is securely attached.



4. Be Sure the Harness Straps Are at the Proper Height

Rear-Facing: Harness straps must be **at or just below** the child's shoulders and top of head **must be at least 1" (2.5 cm) below** headrest/harness adjustment handle.

Forward-Facing: Harness straps must be **at or just above** the child's shoulders and top of child's ears must be **below** top of headrest.



Rear-Facing

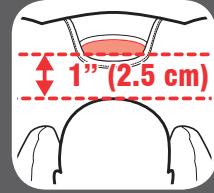

Forward-Facing



To Raise or Lower Headrest/ Harness Height

Squeeze the adjustment handle and move headrest for the proper harness height.

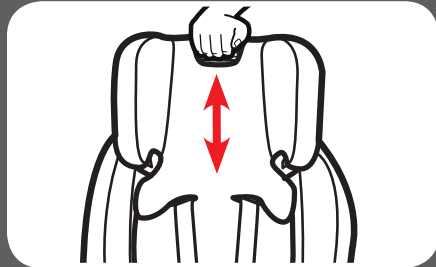
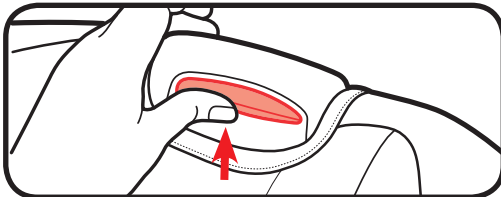

5. Check the Buckle Position

The correct slot is the one that is closest to your child without being underneath them.

To Adjust, Lift the Lower Seat Pad From Front of Car Seat to Expose The Buckle Slots

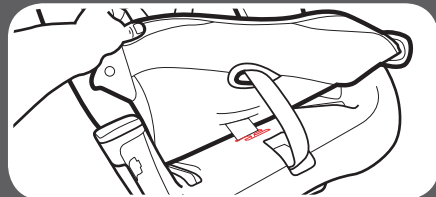
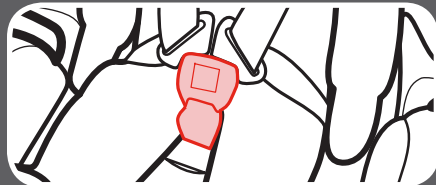

**6 Securing
Child**

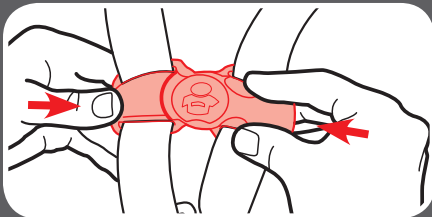
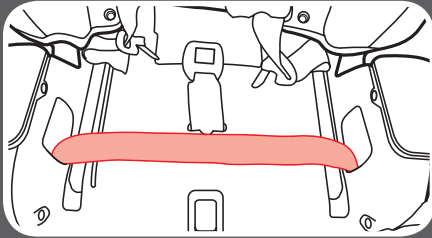
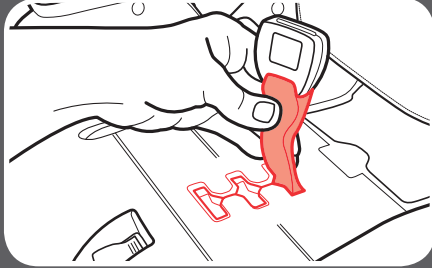
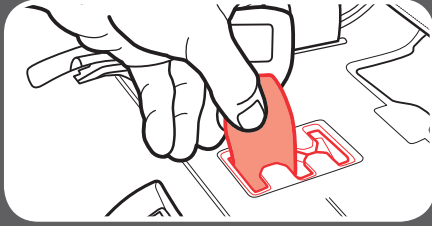

Turn Buckle Strap Sideways and Slide to Desired Slot

Make sure buckle strap is in one of the three positions.

Make Sure Lower Anchor Strap is in Front of Buckle Strap

6. Replace Seat Pad, Making Sure the Buckle Goes Through the Same Slot in the Seat Pad as in the Plastic Shell

7. Buckle the Chest Clip

You will hear a “click” when the chest clip is securely buckled.



8. Pull All the Slack Out From Around the Waist

Pull up on the harness strap while pushing the chest clip down. Do this to both sides.

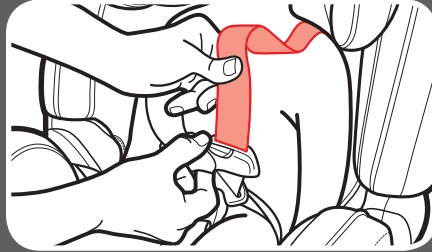

9. Tighten the Harness by Pulling the Harness Adjustment Strap

A snug harness should not allow any slack. It lies in a relatively straight line without sagging. It does not press on the child's flesh or push the child's body into an unnatural position.

When you are not able to pinch any of the harness webbing at your child's shoulder, the harness is tight enough.

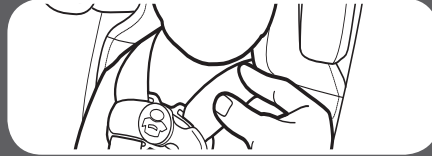
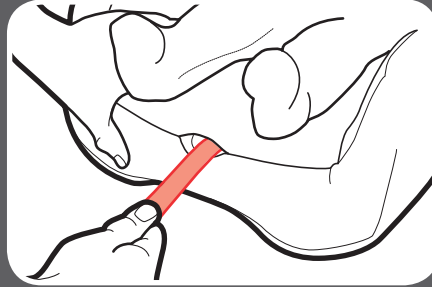

10. Raise the Chest Clip to Child's Armpit Level

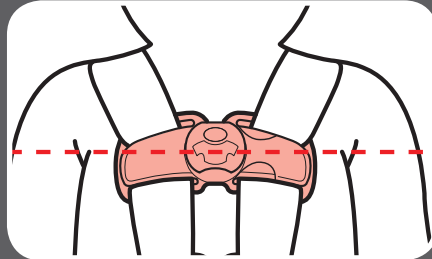

11. Check Tightness

Tighten more if needed.

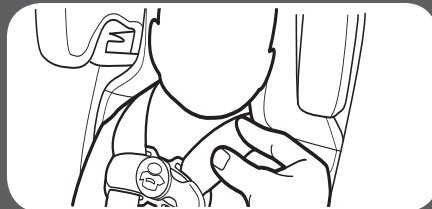



6-B Securing Child In Booster

WARNING! Use only the vehicle's lap and shoulder belt system when restraining the child in this booster seat.

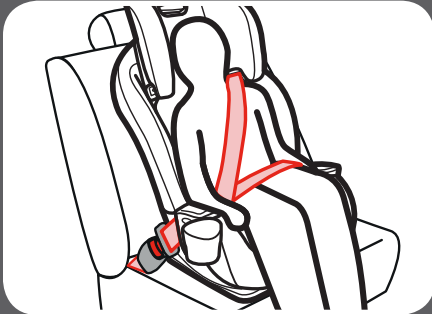
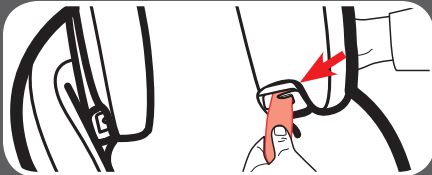

1. *Place Child In Seat*

Have your child sit in the booster seat, with their back flat against the back of the booster seat.

2. *Thread Vehicle's Shoulder Belt Through Booster Shoulder Belt Guide in the Headrest*

3. *Buckle the Vehicle's Lap/Shoulder Seat Belt*

Be sure the lap portion of the vehicle seat belt goes behind the armrests. Both the lap and shoulder belt must lay in the booster belt path on the buckle side of the seat.

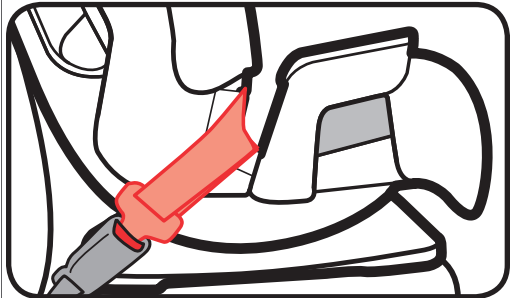

Be sure the lap portion of the vehicle seat belt is low across your child's hips.

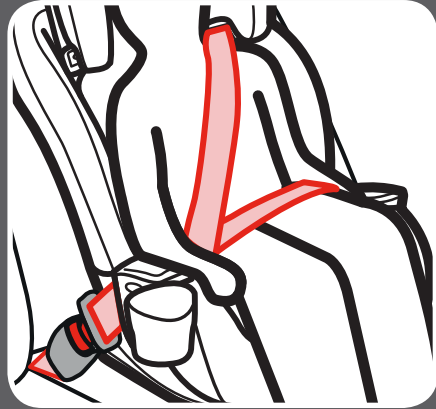

Vehicle seat's shoulder belt should be centered between the child's neck and edge of shoulder.

Raise or lower the headrest to change the shoulder belt location on the child.

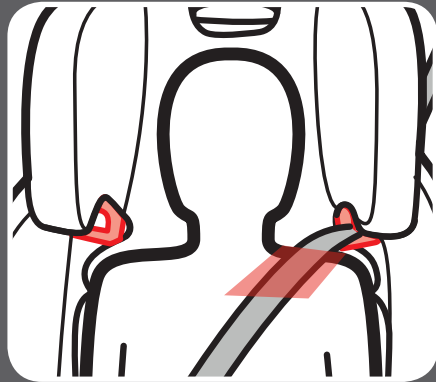

7-A Moving Lower Anchor Attachment

1. For Ease of Moving the Lower Anchor Strap

- A. Loosen the harness straps.
- B. Raise the headrest to the highest position.
- C. Unbuckle the chest clip.
- D. Unbuckle the buckle.

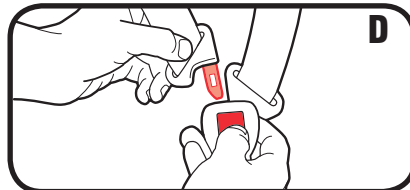
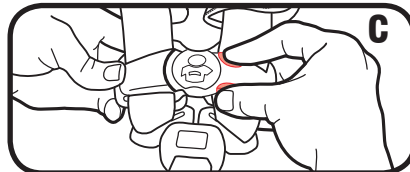
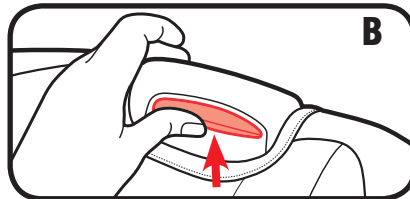
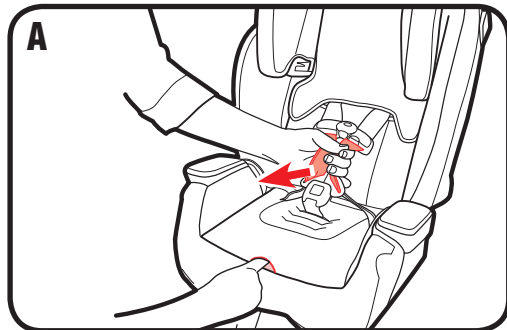

2. Remove the Lower Seat Pad to Expose the Lower Anchor Strap

Note the orange and blue labels at the top and bottom of the red bar (G).

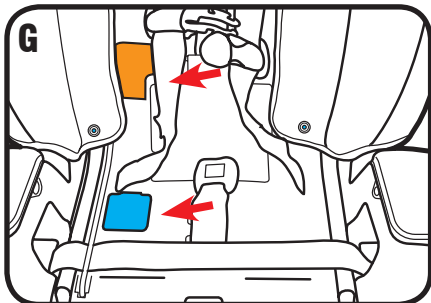
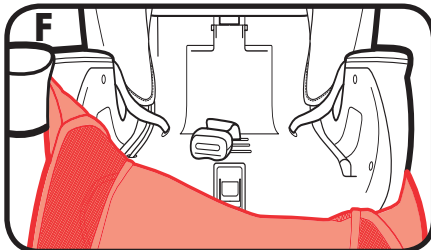
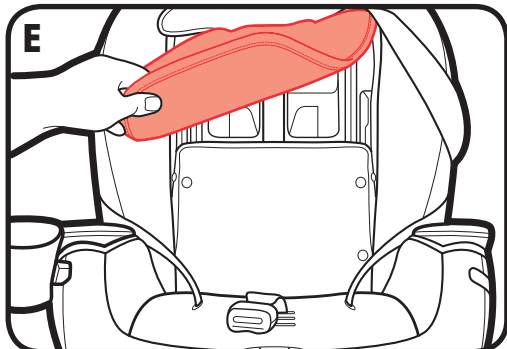

3. Pull the Lower Anchor Connectors Out of the Belt Path Openings into the Center of the Car Seat

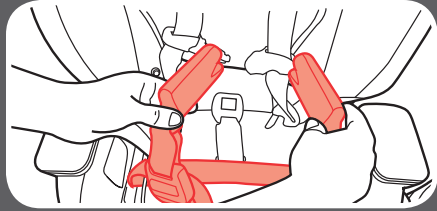

4. Slide Entire Lower Anchor Strap Along the Red Bar to the Desired Belt Path Openings

Rear-Facing: Slide the Lower Anchor strap down to the blue label at the bottom of the red bar.

Forward-Facing: Slide the Lower Anchor strap up to the orange label at the top of the red bar.

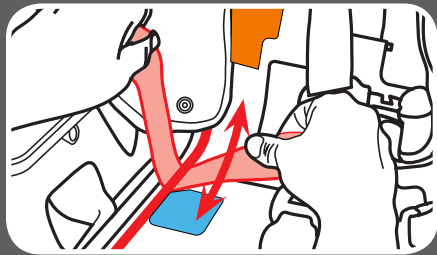

5. Push the Lower Anchor Connectors Out Through the Desired Belt Path Openings on Each Side of Car Seat

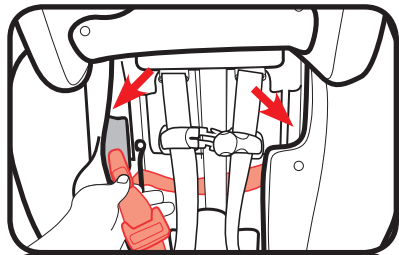

OR

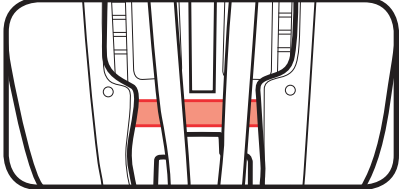
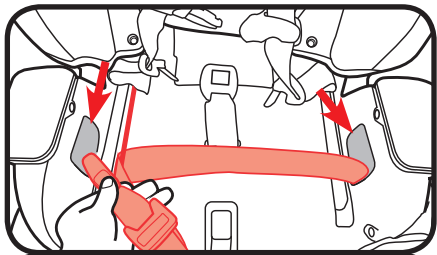

Forward-Facing: Make sure the Lower Anchor strap is routed behind the harness strap, is flat, and is not twisted.

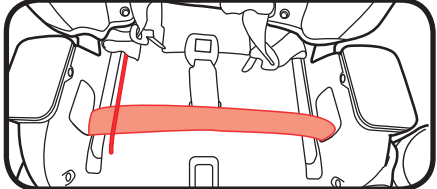

Rear-Facing: Make sure the Lower Anchor strap is in front of the buckle strap, is flat, and is not twisted.

**7 Moving
Lower Anchors**

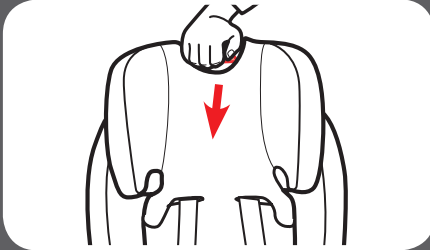
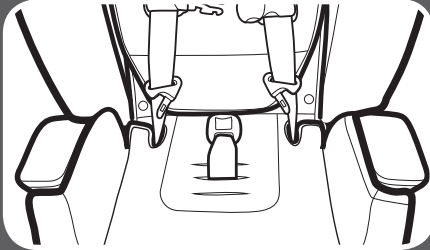

6. Replace Seat Pad

**7. Move the Headrest to Its Proper
Position for Your Child**

8-A Accessories *(on select models)*

Headrest Support

To remove, unhook the elastic straps on the sides of the headrest.

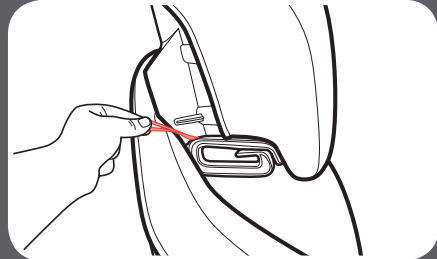
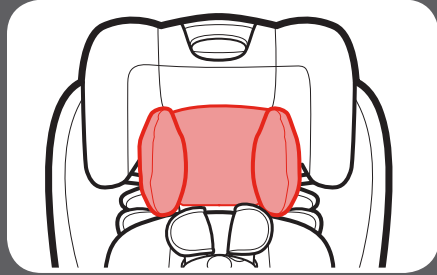

Harness Covers

Make sure that harness covers do not interfere with placement of the chest clip at armpit level.

To remove, undo the fastening strips and remove.

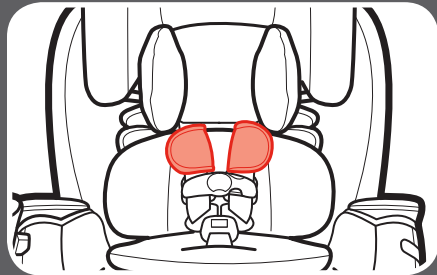

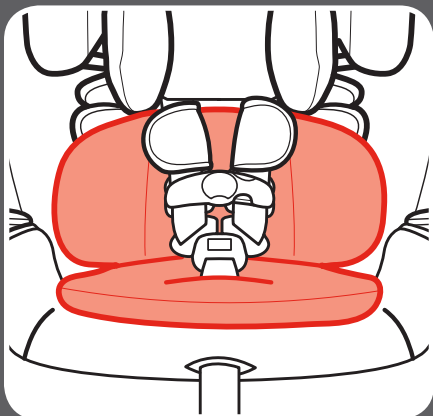

Body Support

Body support must be used if shoulders are below the lowest harness setting.

Never allow body support to bunch or fold behind child.

To remove, unbuckle the buckle and pull out the body support.

Use Body Support only in the rear-facing mode.

Cup Holder

Cup holder can be on either side.

To attach, pull back the seat pad to expose the attachment guide (1). Slide the cup holder down the guide until it locks into place (2).

To remove, place both hands under the cup holder and push up on the cup holder (3).

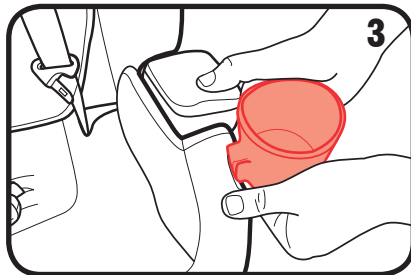
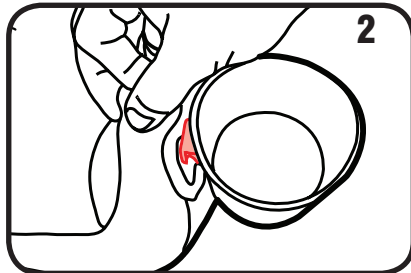
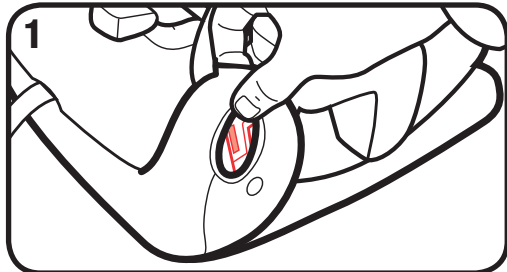

9-A Choosing Vehicle Seat Location

Review your vehicle owner's manual for seating locations.

The best seating location for this car seat is one that:

- Is recommended by your vehicle owner's manual, and
- Results in a secure installation of this car seat.

According to accident statistics, the safest place for your child in any vehicle is the back seat. The center of the back seat can be the safest during a possible side impact.



Some vehicles have specific requirements for where the car seat can be installed, so be sure to check your vehicle owner's manual for available seating positions, if any. For example, sometimes the center rear seat has a lap only vehicle seat belt, which cannot be used when this car seat is in Booster mode.

In the event there is no available back seat and / or you have no other option than to place a child other than an infant in a rear-facing car seat in a front passenger seating position, the National Highway Traffic Safety Administration (NHTSA) recommends that you take the following steps:

- Ensure the child is properly restrained according to their age and size.
- Move the seat as far back as possible.
- Make sure the child is not leaning out of position, such as leaning forward into the deployment path of the air bag.
- Set the air bag ON-OFF switch, if available, to the OFF position.

9-B Unsafe Vehicle Seat Locations

Never install this car seat in any of the following vehicle seating locations:



rear-facing or side-facing
vehicle seats



rear-facing with an
active front air bag



booster mode with vehicle lap
only seat belt

9-C What is LATCH?

This car seat can be installed using your vehicle's LATCH system, if your vehicle is equipped with LATCH. All 2003 and newer model year vehicles are required to have a LATCH system, although some manufacturers began including LATCH earlier. Some vehicle owner manuals use the term ISOFIX to identify the LATCH system.

LATCH consists of lower anchors and tether anchors, which are built-in to your vehicle, and connecting hooks that are built-in to your car seat. Lower anchors are used **INSTEAD** of the vehicle's seat belt to secure the child seat to the vehicle. Tethers are used **IN ADDITION** to the lower anchors **OR** the vehicle's seat belt to secure a forward-facing car seat to the vehicle.

Review your vehicle's owner manual for exact location and use.

**Vehicle Tether
Anchor Points**

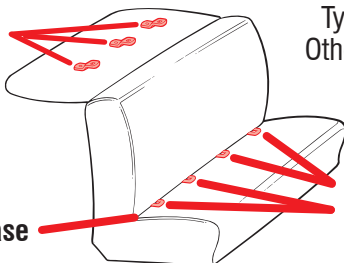

Typical seat in a passenger vehicle.
Other vehicle types may have different
lower anchor and tether
locations.

Vehicle Seat Crease

**Vehicle Lower
Anchor Points**



The lower anchors can **ONLY** be used if the vehicle lower anchor spacing is 11 inches (28 cm) from the center of one lower anchor to the center of the other lower anchor.

9-D Choosing Lower Anchor Attachment or Seat Belts

This car seat can be installed in your vehicle using either the vehicle seat belt OR the Lower Anchor Attachment system.

The Lower Anchor Attachment system allows you to securely attach your car seat in your car without using the vehicle seat belt and possibly to get a better fit.

For seating positions equipped with Lower Anchors, experts recommend trying the Lower Anchor installation first and only using the seat belt in that seating position if Lower Anchors, for some reason, results in a looser fit. If you want to use the center rear seat and Lower Anchors are not available in that position (check the vehicle owner's manual), try the seat belt to be sure you can get a tight installation. If you cannot, try using Lower Anchors in a different seating position. Remember to only use Lower Anchors in seating positions recommended by your vehicle manufacturer.

Do not use the lower anchors of the child restraint anchorage system (LATCH system) to attach this child restraint when restraining a child weighing more than 45 lbs (20 kg) with the internal harnesses of the child restraint.

9-E How to Remove Lower Anchors and Tether

Lower Anchors

To remove the Lower Anchor connectors from the lower anchors, push in on the red buttons and pull them off.

Tether Strap

To remove, lift up on the tether lock to release the tension.

Press in on the hook's spring. Push tether hook in, then lift up and pull away from tether anchor.

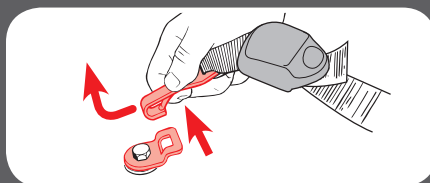
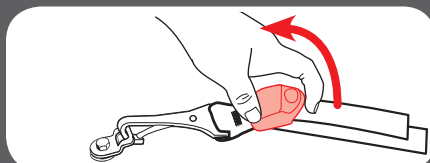

9-F Vehicle Seat Belts

Review your vehicle owner's manual for vehicle seat belt use

This car seat can be installed using a vehicle seat belt. To do this, you will need to change the seat belt to a locked mode for use with car seats. With some vehicle seat belts, this is done with the latchplate; with other vehicle seat belts, this is done with the retractor.

Vehicle Seat Belt Terms

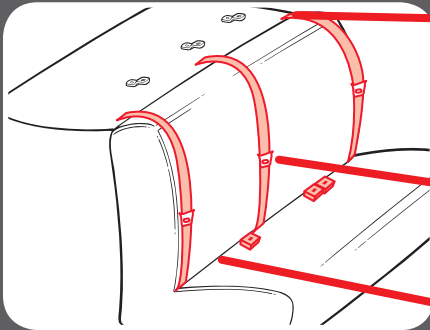

Retractor

A device that winds up the unused vehicle seat belt. It is often hidden inside the panels on the walls of the vehicle or in the vehicle seat back.

Latch Plate

The male end of the seat belt with the silver tongue.

Seat Crease

The crease where the vehicle seat back and seat bottom meet.

Identify Your Seat Belt Type

There are two different types of vehicle seat belts that can be used with this car seat:

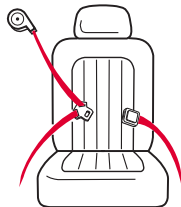

Lap/Shoulder Seat Belt

3 connection points. Can be used in all car seats modes of use.

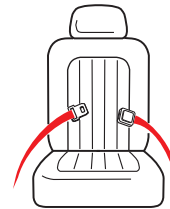

Lap Only Seat Belt

2 connection points. **Can ONLY be used in harness mode.**

The following types of vehicle seat belts **CANNOT** be used safely with this car seat:



Lap Belt with Motorized Shoulder Belt



Lap Belt or Shoulder Belt Mounted on Door

Belts Forward of the Seat Crease

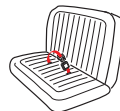

Some vehicles you may not get a secure fit. Read both your vehicle and car seat manuals.

Lap/Shoulder Seat Belt Installation - Harness Mode

Always review your vehicle owner's manual for specific information about your vehicle seat belts.

There are three types of retractors: **ELR (Emergency Locking Retractor)**, **ALR (Automatic Locking Retractor)**, and **Switchable (ELR switch to ALR)**. To determine your type of retractor, follow these steps:

1. **Slowly** pull the belt out about halfway and stop.
2. Let the belt retract back several inches.
3. Try to **slowly** pull the belt out more. If the belt cannot be pulled any further, it is **ALR**. If it can be pulled further, go to the next step.
4. **Slowly** pull the belt all the way out, and then allow it to retract several inches.
5. Try to pull the belt all the way out again. If it cannot be pulled out, it is **Switchable**. If it can still be pulled out freely, it is **ELR**.

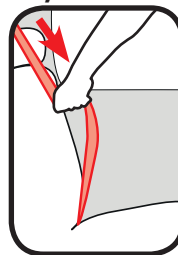

Note: Most vehicles manufactured after 1996 will have Switchable retractors in the back seat. If you have any questions about your retractor type, consult your vehicle owner's manual or call Graco for assistance.

How to Lock Your Lap/Shoulder Vehicle Seat Belt

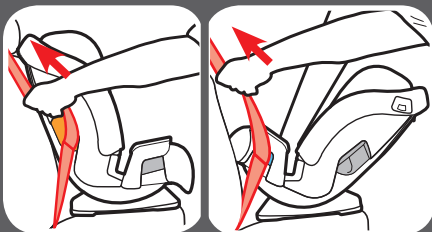
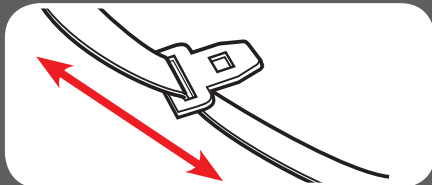

Note: With the vehicle seat belt in this locking mode, all the tension is upwards in the shoulder belt. This may start to tilt your car seat sideways. If this happens, use a locking clip instead of switching the retractor. See Sliding Latch Plate and ELR Retractor.

Sliding Latch Plate and Switchable Retractor

A latchplate that slides freely on the belt webbing and cannot, by itself, hold the belt snug around a car seat.

When installing the car seat, route the vehicle seat belt through the proper belt path and buckle it in. **Slowly pull the shoulder belt all the way out to switch it to locking mode.** Then, as you pull the vehicle seat belt tight, feed all the slack back into the retractor.

Grab the sides of the seat at the belt path and slide the seat side to side and front to back. The seat should not move more than 1" (2.5 cm).

Locking Latchplate and ELR Retractor

A latchplate that holds the lap belt snug after it has been adjusted; contains a metal bar on the underside of the hardware that "locks" the belt in position.

When installing the car seat, route the vehicle seat belt through the proper belt path and buckle it in. Then, pull upwards on the shoulder belt so that the lap belt gets tight around the car seat.

Grab the sides of the seat at the belt path and slide the seat side to side and front to back. The seat should not move more than 1" (2.5 cm).

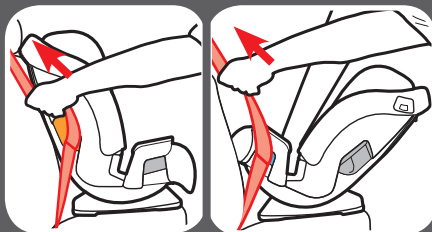
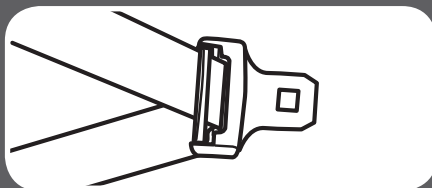

Sliding Latch Plate and ALR Retractor

A latchplate that slides freely on the belt webbing and cannot, by itself, hold the belt snug around a car seat.

Slowly pull the shoulder belt all the way out. Route the vehicle seat belt through the proper belt path and buckle it in. Then, as you pull the vehicle seat belt tight, feed all the slack back into the retractor.

Grab the sides of the seat at the belt path and slide the seat side-to-side and front-to-back. The seat should not move more than 1" (2.5 cm).

Sliding Latch Plate and ELR Retractor

A latchplate that slides freely on the belt webbing and cannot, by itself, hold the belt snug around a car seat.

With this retractor, you will need to use the locking clip to lock the vehicle seat belt.

To obtain a locking clip call 1-800-345-4109.

Route the vehicle seat belt through the proper belt path and buckle it in. Pull the vehicle seat belt tight. While pushing down on seat, pinch the two straps together behind the buckle tongue. Unbuckle the belt without allowing it to slip.

Attach locking clip to lap and shoulder belts as shown.

Rebuckle belt. Check that lap belt does not move by pulling hard. If belt loosens or lengthens, repeat procedure.

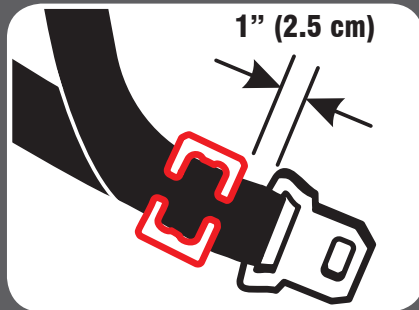
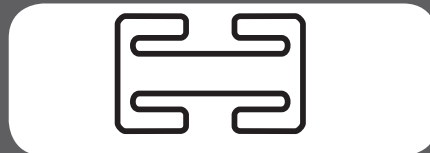
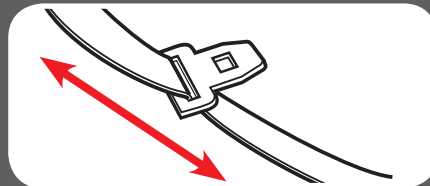
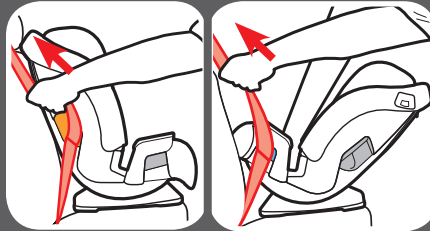
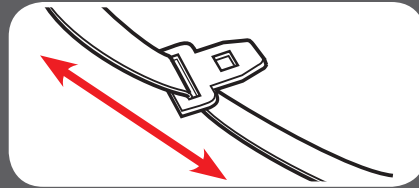

Lap Belt Installation - DO NOT use in Booster Mode

Always review your vehicle owner's manual for specific information about your vehicle seat belts.



Grab the sides of the seat at the belt path and slide the seat side to side and front to back. The seat should not move more than 1" (2.5 cm).

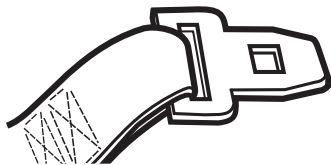

Locking Latch Plate and No Retractor

When installing the car seat, route the lap seat belt through the proper path and buckle it in. Then, pull upwards on the tail of the belt so that the lap belt gets tight around the car seat.

Sewn On Latch Plate and ALR Retractor

Slowly pull the lap belt all the way out. Route the vehicle seat lap belt through the proper belt path and buckle it in. Then, pull the lap belt tight while feeding all the slack back into the retractor.

10-A Cleaning Seat Pad

Clean with a damp sponge using mild soap and cool water. Refer to seat pad care tag for washing instructions.

Headrest Pad

If needed, headrest pad may be removed for cleaning.

Pull the plastic tab out of the slots just below the headrest adjustment handle.

Remove the elastic straps from the hooks on both sides of the headrest.

Pull pad off of headrest.

Machine wash cover in cold water on delicate cycle and drip-dry. **DO NOT USE BLEACH.**

Reverse the steps to reattach the cover on the headrest.

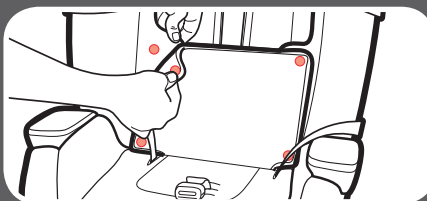
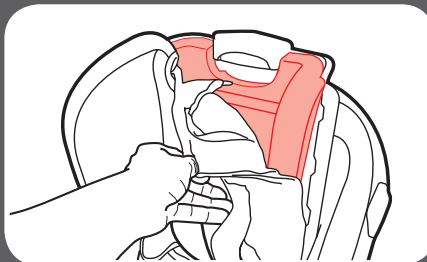
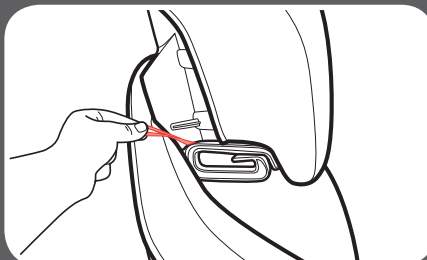
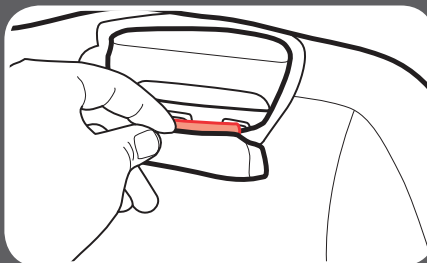

Lower Seat Pad

If needed, lower seat pad may be removed for cleaning.

To remove, unsnap lower seat pad from side pad.

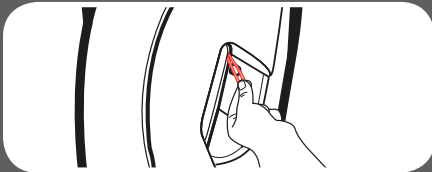
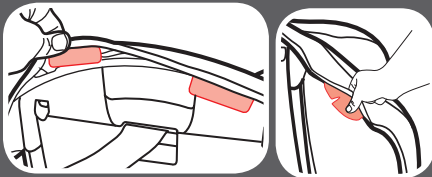
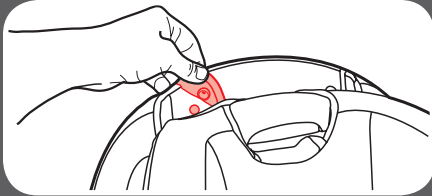
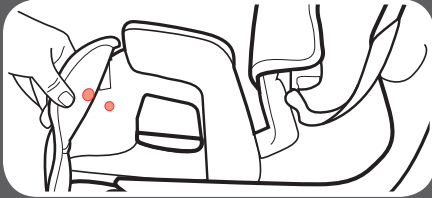
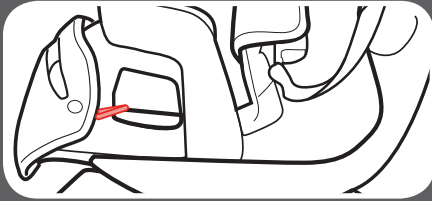

Remove the elastic straps from the hooks on both sides of the seat pad.

Unsnap the pad from the armrests.

Undo the plastic hooks on both armrest.

Pull the pad off.

Machine wash cover in cold water on delicate cycle and drip-dry. **DO NOT USE BLEACH.**

Reverse the steps to reattach the bottom seat pad. Place front of the plastic shell in the pocket in the pad.

Side Pad

If needed, side pad may be removed for cleaning.

To remove, lower headrest and unsnap the pad from back.

Pull the plastic tabs out from the back and sides of the seat.

Pull the pad off.

Machine wash cover in cold water on delicate cycle and drip-dry. **DO NOT USE BLEACH.**

Reverse the steps to reattach the bottom seat pad. Place the corner of the sidewing in the pocket at the bottom of the side pad.

10-B Cleaning Crotch Buckle

Recline the car seat and locate the metal retainer. Rotate the metal retainer up through the shell and pad. From the front, pull out the buckle.

To clean buckle, place in a cup of warm water and gently agitate the buckle. Press the red button several times while in the water.

DO NOT SUBMERGE THE BUCKLE STRAP. DO NOT USE SOAPS, HOUSEHOLD DETERGENTS or LUBRICANTS.

Shake out excess water and allow to air dry. Repeat steps as needed until it fastens with a click. Re-insert the buckle into the same slot it was removed. Pull up on buckle to make sure it is secured.

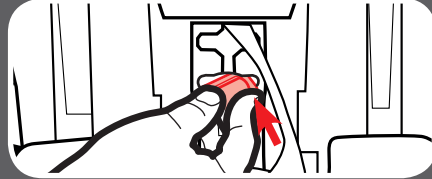

WARNING! Inspect and clean buckle from time to time to remove any objects or debris that could prevent latching.

10-C Cleaning Harness, Lower Anchor and Tether

Surface wash only with mild soap and damp cloth. **DO NOT IMMERSE THE HARNESS STRAPS or LOWER ANCHOR STRAP IN WATER** Doing so may weaken the straps.

If harness straps or Lower Anchor belt are frayed or heavily soiled, contact Customer Service at www.gracobaby.com or 1-800-345-4109.

NOTES:

NOTES:

Replacement Parts

To purchase parts or accessories in the United States,
please contact us at the following:

www.gracobaby.com

or

1-800-345-4109



Store instruction manual in the
slot with the instruction book
icon as shown.

